

1670097

*Models 167, 177, 168, 457, 458, 764, 765, 784, 787*



# ***Snack/Refreshment Center 2***

## ***Snack Center 4***



797  
798



784  
787

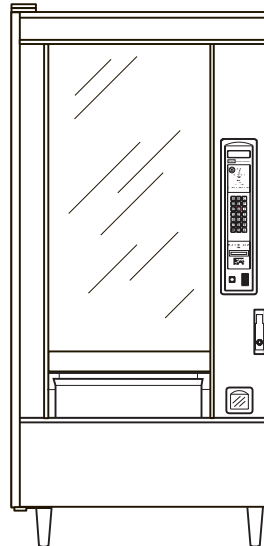

168  
458  
765

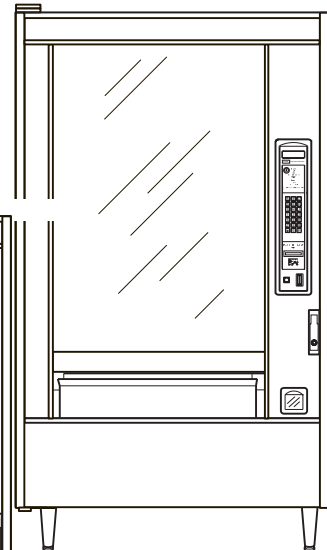

167  
177  
457  
764

## **Set-Up & Operators' Guide**

**CRANE** MERCHANDISING SYSTEMS A Crane Co. Company  
**NATIONAL VENDORS**

12955 Enterprise Way  
Bridgeton, Missouri 63044-1200  
(314) 298-3500 / Service: (800) 628-8363  
[www.CraneMS.com](http://www.CraneMS.com)

# How to use this guide

Since your merchandiser came equipped with a can module, the Snack Center *Setup and Operator's Guide* has instructed you to get this booklet to continue your setup. Follow the steps for setting up your can module, then return to the spot in the *Setup and Operator's Guide* that sent you here. You may notice some other books in your plastic bag, also. The *Programming Guide* is a reference for you to use later, after your machine is up and running. Use the *Programming Guide* to access the many advanced features included with your machine.

**DO NOT DISPOSE OF THIS BOOKLET!** Even though you may have finished with it today, you might find the need to set your merchandiser up again. We recommend returning it to the plastic bag, and storing it inside the cabinet. That way, it is readily available at a future time.

This machine has been engineered to our own rigid safety and performance standards. It has been designed to comply with sanitation and health guidelines recommended by the Automatic Merchandising Health-Industry Council (AMHIC) and it conforms with all other NAMA safety recommendations.

This machine has been manufactured in accordance with the safety standards of both Underwriter's Laboratories and the Canadian Standards Association. To maintain this degree of safety and to continue to achieve the level of performance built into this machine, it is important that installation and maintenance be performed so as to not alter the original construction or wiring, and that replacement parts are as specified in the *Parts Manual*. Your investment in this equipment will be protected by using this *Setup and Operator's Guide* and the *Parts Manual* in your operation, service and maintenance work. By following the prescribed procedures, machine performance and safety will be preserved.

**Table of Contents**

---

**Preliminary** ..... 5

**Initial Set-Up** ..... 9

**1. MOVE THE MERCHANDISER THROUGH A NARROW DOORWAY** ..... 9

        remove the top panel: 9

        remove the bottom panel: 9

        take the merchandiser through the opening: 10

        reassemble the merchandiser: 10

**2. POSITION THE MERCHANDISER**..... 10

**Snack Section Set-Up**..... 12

**1. PLACE A TRAY IN THE LOADING POSITION**..... 12

**1. SET UP TRAYS TO VEND PRODUCTS**..... 13

**2. SET UP A TRAY TO VEND WIDE PRODUCTS**..... 13

**3. REMOVING A TRAY** ..... 14

**4. REMOVING AND INSTALLING COLUMN DIVIDERS** ..... 16

**5. OPERATE A TRAY OUTSIDE THE MACHINE**..... 16

**1. REPLACING A MOTOR WITH A SPIRAL BEARING** ..... 17

        removing a motor: 17

        installing a spiral bearing: 17

        disconnecting a motor harness: 18

        connecting a motor harness: 18

**2. CONNECTING AND DISCONNECTING A MOTOR HARNESS** ..... 18

**3. REMOVING AND INSTALLING SPIRALS** ..... 19

        to remove a spiral: 20

        to install a spiral: 20

        should i use a clockwise or a counterclockwise spiral? 20

**1. REMOVING A SPIRAL COUPLER** ..... 21

        22

**1. REMOVING AND INSTALLING A SPIRAL MOTOR** ..... 22

        removing a spiral motor: 22

        installing a spiral motor: 22

        when are gears used? 23

        where are the gears placed? 23

        how is the gear oriented? 23

**2. INSTALLING A GEAR**..... 23

**3. INSTALLING A SPIRAL COUPLER**..... 24

**4. MOVING A TRAY UP OR DOWN**..... 26

**5. INSTALLING A TRAY IN THE MERCHANDISER** ..... 27

**10. INSTALLING AND REMOVING A PRODUCT SPACER** ..... 28

        loading a tray with products in general: 29

        special considerations: 29

**1. LOAD TRAYS WITH PRODUCT**..... 29

        spiral wall retainer usage: 30

**B.. LOAD TRAYS WITH PRODUCT (CONTINUED)**..... 31

        preparing the merchandiser for vending "lunch bucket": 31

        preparing the merchandiser for vending "top shelf": 32

**1. RETURN THE TRAYS TO THE VENDING POSITION**..... 33

**Table of Contents**

---

installing price labels: 34

**2. INSTALL AND SET PRICE LABELS..... 34**  
adjusting the price roll: 35  
installing selection id numbers: 36

**3. INSTALL SELECTION ID LABELS ..... 36**  
which id label goes with which selection? 37

**Set Up The Gum and Mint Unit ..... 38**

**1. INSTALL PRICE LABELS ..... 38**

**2. PUT THE GUM AND MINT DISPENSER IN THE LOADING POSITION..... 38**

**3. LOAD THE GUM AND MINT DISPENSER WITH PRODUCT ..... 39**

**5. REMOVING AND INSTALLING COLUMN REDUCERS..... 40**  
to remove a column reducer: 40  
to install a column reducer: 40

**4. RETURN THE GUM AND MINT DISPENSER TO THE VENDING POSITION..... 40**

**Final Installation ..... 41**

**1. LEVEL THE MERCHANDISER..... 41**  
method 1: 42  
method 2: 42

**1. INSTALL THE BASE PLATE ..... 44**

**3. INSTALL THE OPTIONAL CASH BOX LOCK ..... 45**

**2. INSTALL THE LOCK CYLINDER ..... 45**

**1. SET UP THE COIN MECHANISM..... 46**

**1. LOAD THE COIN MECHANISM ..... 47**

**Programming ..... 48**  
the service keypad 48

**1. SET PRICES ..... 48**

**2. VIEW THE CHILLER OR CAN UNIT TEMPERATURE ..... 48**

**Final Checkout ..... 49**

**1. TEST VEND SELECTIONS..... 49**

**2. OPERATIONAL READINESS CHECK ..... 49**

**4. SPIRAL INDEXING PROCEDURE  
(TWO SPIRALS, ONE OR TWO MOTORS) ..... 50**

**3. SPIRAL INDEXING PROCEDURE (ONE SPIRAL, ONE MOTOR) ..... 50**

**5. TESTING THE BILL VALIDATOR ..... 51**

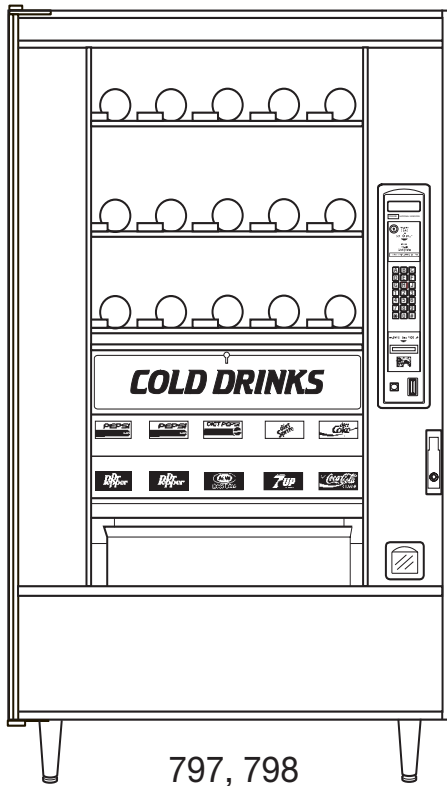

797, 798



784, 787

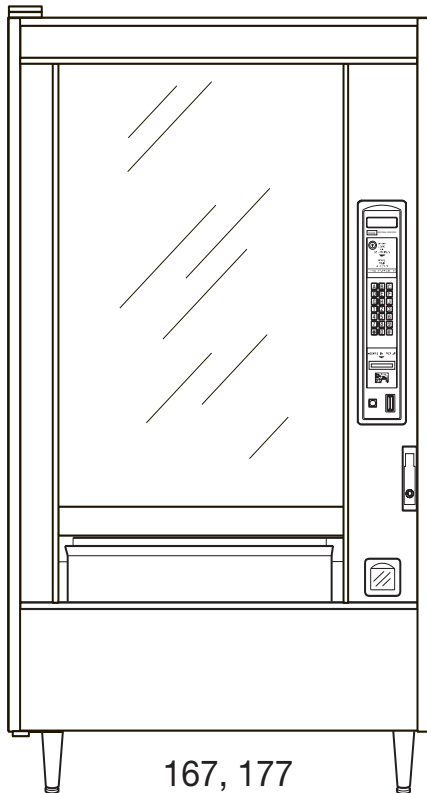

167, 177  
457, 764

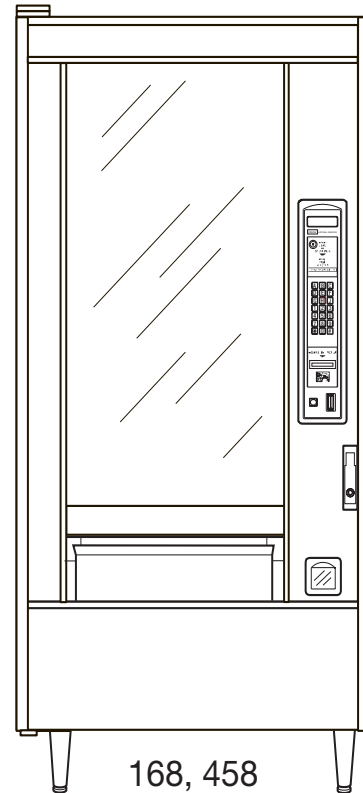

168, 458  
765

157p0296

# Snack / Refreshment Center Setup and Operator's Guide

## Model 168 - Exterior View

(Models 167, 457, 458, 764, 765 have similar appearance)

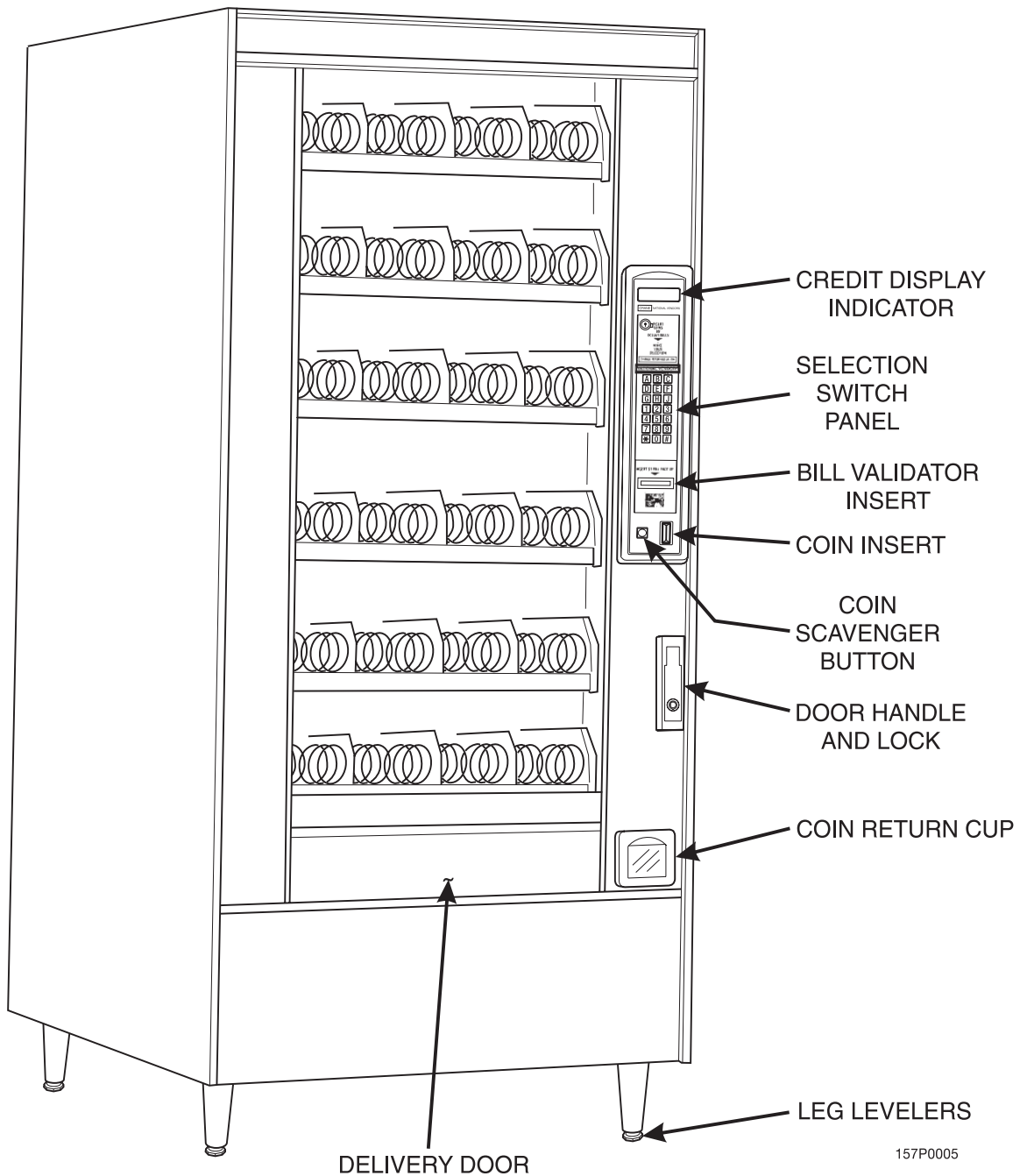

# Snack / Refreshment Center Setup and Operator's Guide

## Model 168 - Interior View (Model 167 has similar appearance)

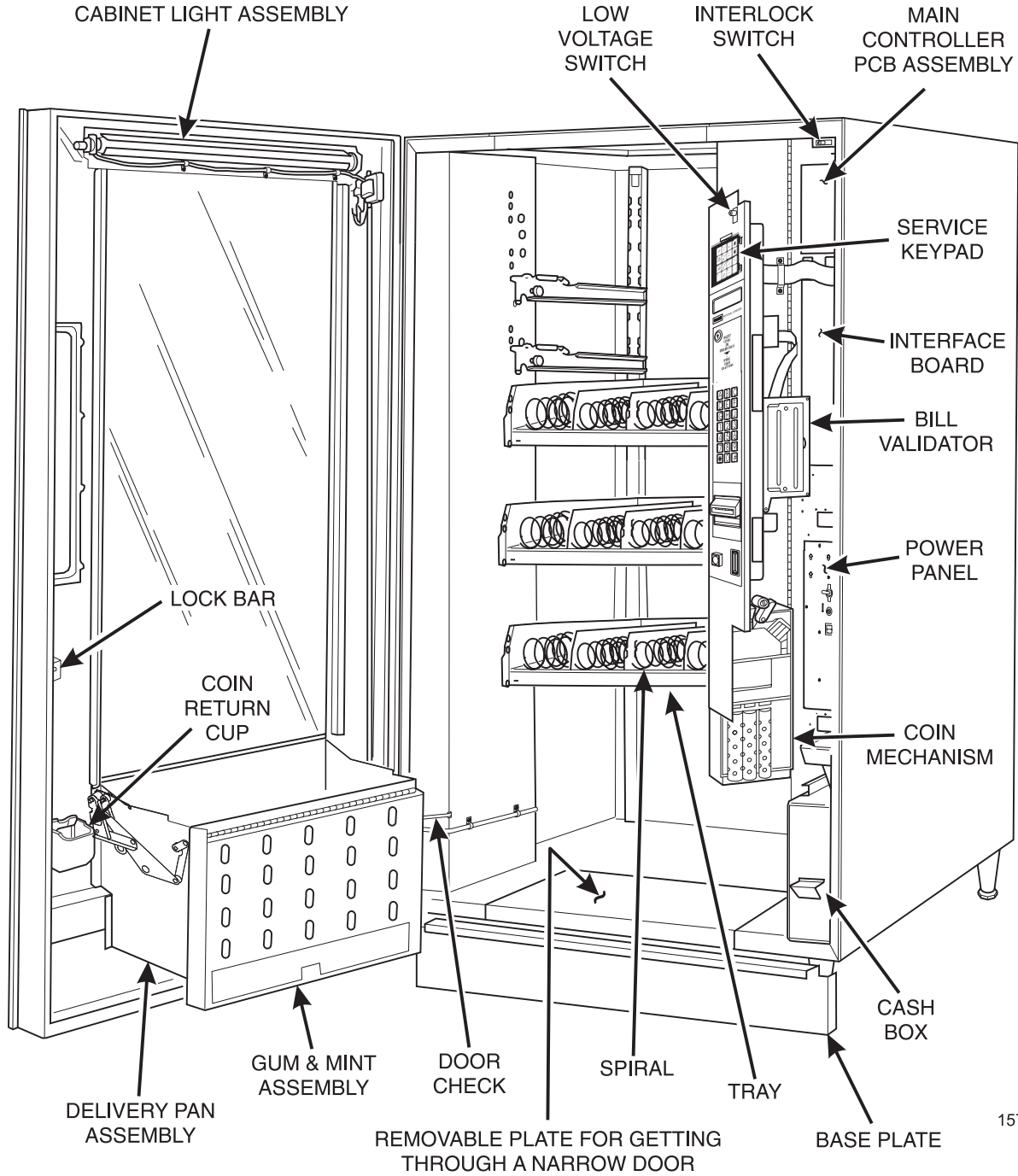

157p0298

# Snack / Refreshment Center Setup and Operator's Guide

## Model 797 - Interior View

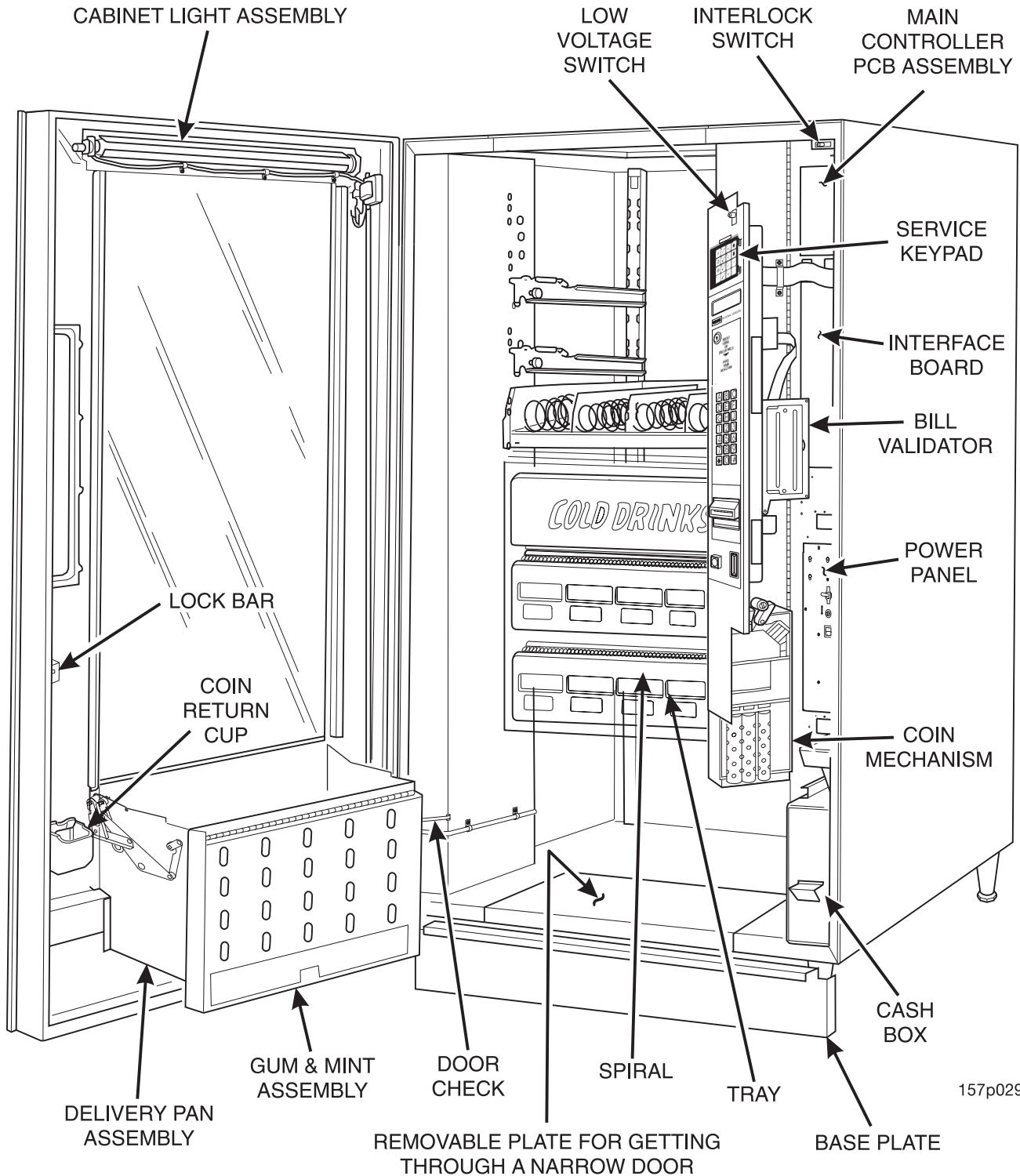

157p0299

# Preliminary

## Power Requirements

The merchandiser is supplied with a service cord for the country of use and is terminated in a ground-ing type plug. The wall receptacle used for this merchandiser must be properly polarized, grounded, and of the correct voltage. Operating the merchandiser from a source of low voltage will **VOID YOUR WARRANTY**. Each merchandiser should have its own electrical circuit and that circuit should be protected with a circuit breaker or fuse conforming to local regulations.

1. **Voltage Check** - Place the leads of a voltmeter across the LINE (LIVE) and NEUTRAL terminals of the wall receptacle. The voltmeter should indicate 110-130 volts ac for 120 volt, 60 Hz locations, or 220- 240 volts ac for 230 volt, 50 Hz locations.
2. **Polarity Check** - Place the leads of a voltmeter across the LINE (LIVE) and GROUND terminals of the wall receptacle. The voltmeter should indicate 110-130 volts ac for 120 volt, 60 Hz locations, or 220- 240 volts ac for 230 volt, 50 Hz locations.
3. **Noise Potential Check** - Place the test leads of a voltmeter across the NEUTRAL and GROUND terminals of the wall receptacle. The meter should indicate 0 volts ac. A measure-ment greater than 1.5 - 2.0 volts ac could result in problems for the merchandiser's electronic circuitry caused by electrical noise.

Any deviation from these requirements could result in unreliable performance from your merchan-diser.

## Unpack the Machine

Remove all packing materials from the interior of the machine. Keep all documents; warranty cards, etc. Set aside the base plate kit (if present).

## Controls and Indicators

**INTERLOCK SWITCH.** When the cabinet door is open, this switch turns off the glass heater, optional fan (if so equipped) and turns on the service light (not present on all models).

**LOW VOLTAGE SWITCH.** Informs the controller software of the main door open or closed status.

**MESSAGE DISPLAY.** This is how the merchandiser communicates with the outside world. Customers can see messages about how much money they have put into the merchandiser. The message display also tells customers when a selection is sold out and when vending is free, inhibited, or discounted. The message display shows you what you are doing when you program the merchandiser, and can show you what is wrong if there is a failure.

**FREE VEND KEYSWITCH (OPTIONAL).** This allows someone (other than maintenance personnel) to set the merchandiser to free vend without opening the door.

**SELECTION SWITCH PANEL.** The customer uses these switches to make selections. Also, maintenance people may use this switch panel during programming and other support modes.

**COIN RETURN BUTTON.** Pressing this button returns any coins that have been paid into the merchandiser prior to a vend.

**BILL ACCEPTOR (OPTIONAL).** Accepts bills in various denominations, depending upon the type of bill validator, and how the machine is configured.

**SERVICE KEYPAD.** The service keypad is located at the top of the monetary panel. It gives service personnel the means to program, retrieve data from, and view diagnostic information about, the merchandiser.

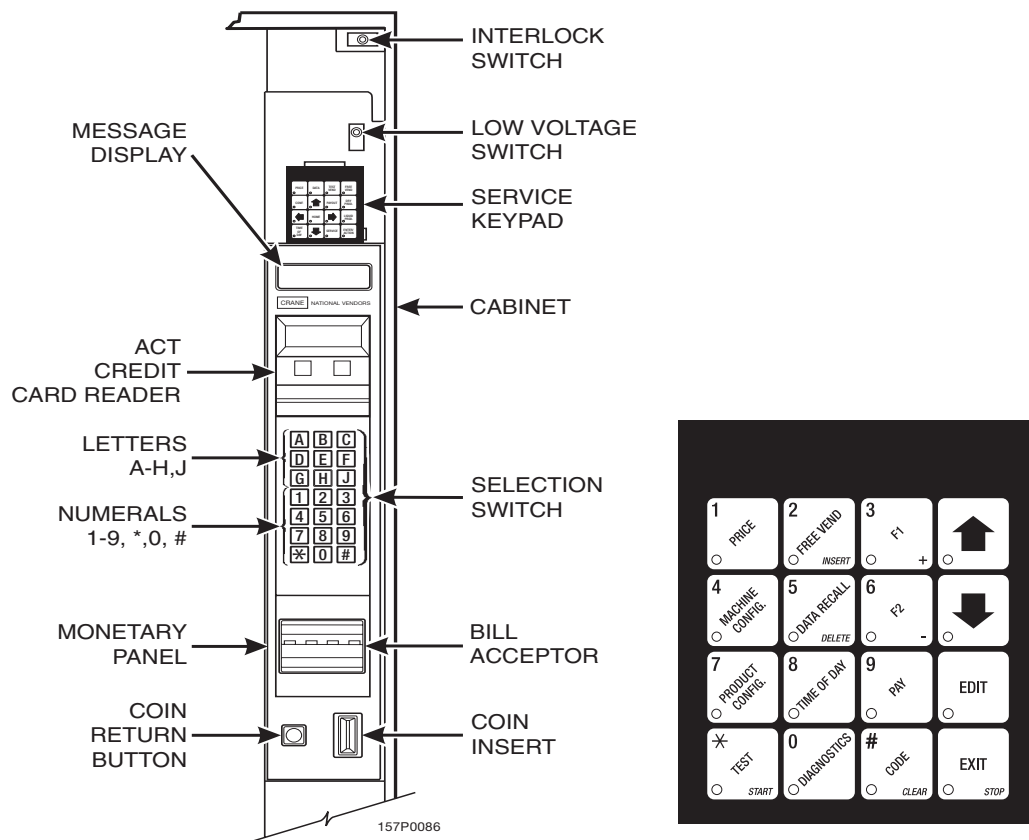

## Controls and Indicators (continued)

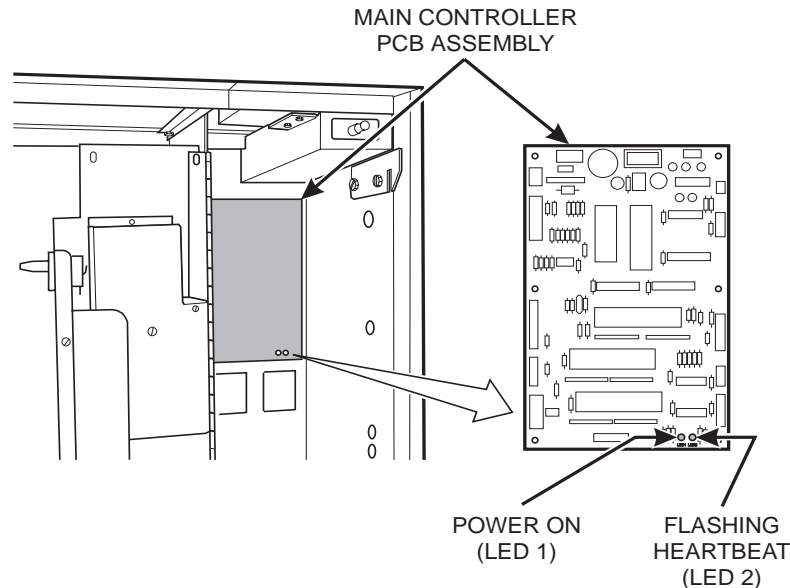

**MAIN CONTROLLER PCB DISPLAY.** This display consists of two light emitting diodes (LED) mounted on the controller PCB.

**POWER ON (L.E.D. 1)** When lit, this red LED indicates electrical power is applied to the controller PCB.

**HEARTBEAT (L.E.D. 2)** When flashing, this red LED indicates that the controller PCB is active, and the software is operating.

**"CAUTION** - Risk of explosion if battery is replaced with an incorrect type. Dispose of used batteries according to the manufacturer's instructions."

### NORMAL CONDITIONS:

When the merchandiser is operating normally, you should see a steady red **POWER ON** indicator and a flashing red **HEARTBEAT** indicator. Contact a service representative if any other condition exists.

**Back Side of U.S./Canada Power Panel.** The circuit board mounted on the rear of the power panel is a dc power supply for the coin mechanism. A fuse protects the board circuitry in the event of a coin mechanism solenoid failure. If the coin mechanism is not working, check this fuse. If the fuse is blown, a bad coin mechanism solenoid could be at fault. (Board may not be there if machine is setup for MDB.)

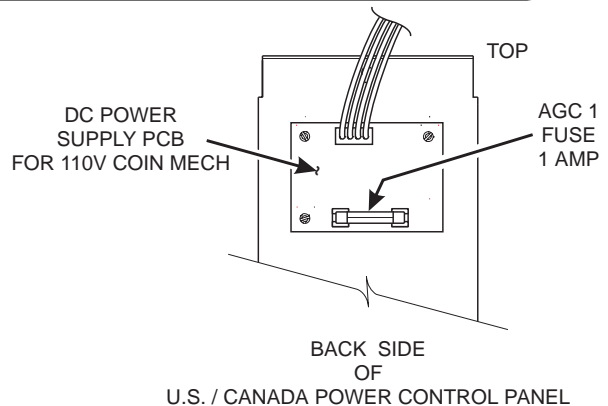

## How to Turn the Merchandiser ON and OFF

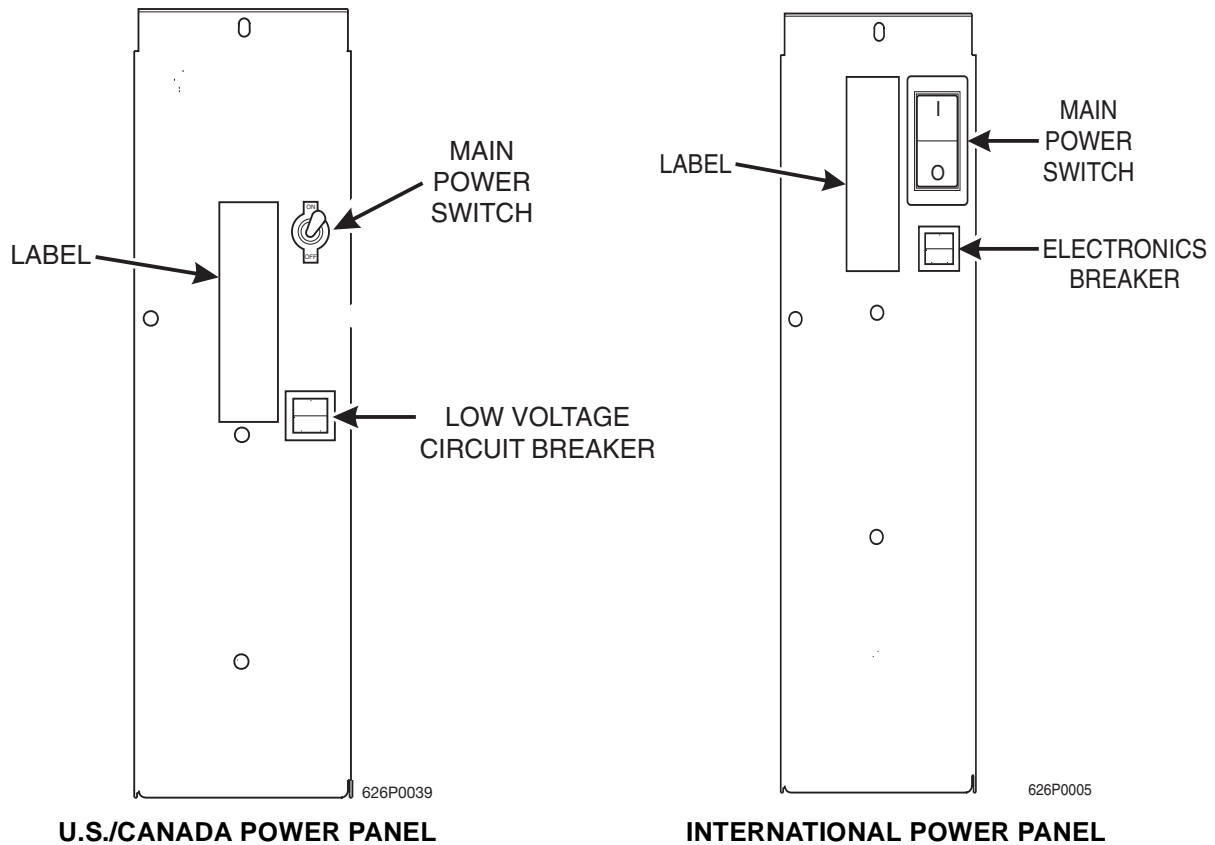

- Power to the merchandiser is controlled by the main power switch, located on the power panel.
- The power panel is on the right side of the merchandiser, behind the monetary door.

### WARNING

**Lethal voltages are present. Unplug the merchandiser whenever you do one of the following tasks:**

- **Change a fuse**
- **Change the fluorescent lamp**
- **Change the lamp starter**
- **Connect or disconnect a harness (except a motor harness when the tray has been removed)**

**Failure to do so may result in personal injury.**

# Initial Set-Up

## 1. Move the Merchandiser Through a Narrow Doorway

**NOTE:** If necessary, this merchandiser can be moved through an opening as narrow as 30 inches by removing panels at the top and bottom of the cabinet. Merchandisers 457 and 458 are only 28" deep, and do not require panels to be removed.

### **REMOVE THE TOP PANEL:**

1. Remove the two screws that secure each end of the panel to the cabinet.
2. Pull the panel forward to remove it from the merchandiser.

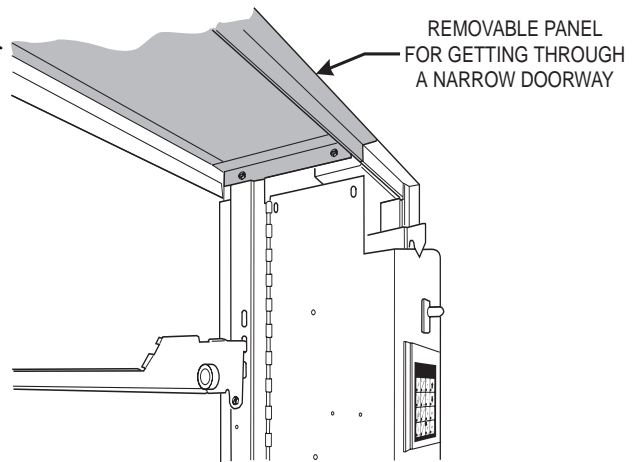

VIEW LOOKING INTO THE TOP OF THE CABINET

### **REMOVE THE BOTTOM PANEL:**

1. Remove the screws that secure the panel to the cabinet.
2. Pull the panel forward to remove it from the cabinet.

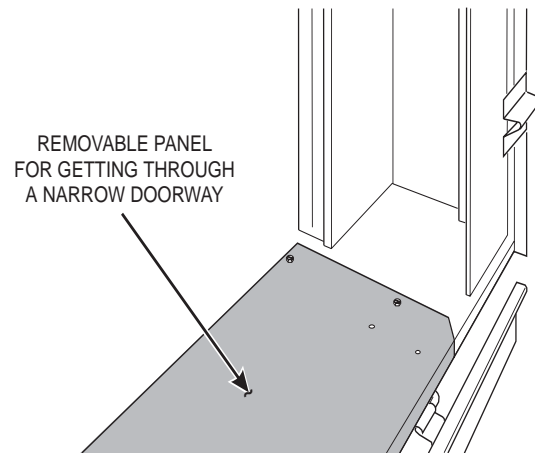

VIEW LOOKING INTO THE BOTTOM OF THE CABINET

## **1. Move the Merchandiser Through a Narrow Doorway (continued)**

### **TAKE THE MERCHANDISER THROUGH THE OPENING:**

1. Open the cabinet door and place it square with the left side of the cabinet.
2. Carefully walk the merchandiser through the opening.

### **REASSEMBLE THE MERCHANDISER:**

1. Replace the upper and lower panels.

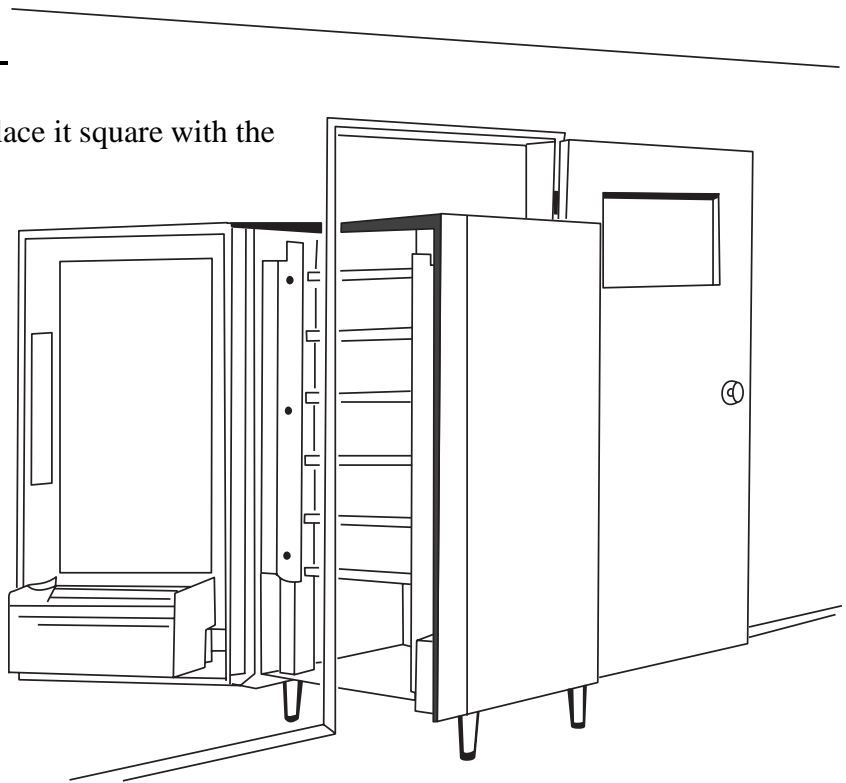

## **2. Position the Merchandiser**

Move the merchandiser to its *approximate position*. (There are some procedures you need to do before it is in its permanent location.) Plug in your merchandiser and turn the power switch to **ON**.

- You can position this merchandiser anywhere in a bank of machines. It can even be placed on an end flush against a side wall.
- The 167 and 168 merchandisers should be located at least one inch away from the back wall.
- The 764, 765, 784, 787, 797, and 798 merchandisers should be placed at least six inches away from the back wall. This will provide adequate air circulation for the refrigeration unit.
- The 764, 765, 787, 797, and 798 merchandisers will operate more efficiently when placed in a shaded location.
- There should be enough room in front of the merchandiser for the door to move freely.

### **WARNING**

**This machine is only rated for installation in an indoor location.**

**Time Out!**

Now that you have placed your machine near its permanent location, you need to set up some of the special options you may have.

**NOW, IF YOUR MACHINE IS EQUIPPED WITH A CAN-MODULE . . .**

Grab the booklet entitled "*CAN MODULE SETUP AND OPERATOR'S GUIDE*" and follow the setup procedures contained in it. After you have done that, come right back here and proceed with the next step.

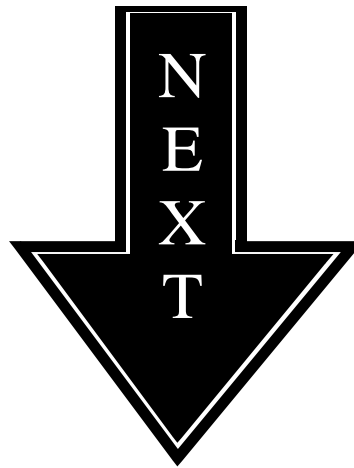

Go on to the next page and continue with the snack set up.

# Snack Section Set-Up

## 1. Place a Tray in the Loading Position

2. Place both hands on the tray as shown.
3. If your machine has tray latches, lightly push back on the tray with your palms. This will release the tray latches on the sides of the tray. Otherwise, skip to step 5.
4. Push down on the tray latches with your thumbs.
5. Pull the tray toward you until you hear and feel the rear tray rollers drop into a cut-out in the top of the guide rail. Skip to step 6
6. Lightly lift the front of the tray and pull the tray toward you until you hear and feel the tray rollers drop into the cut-out in the top of the guide rail.

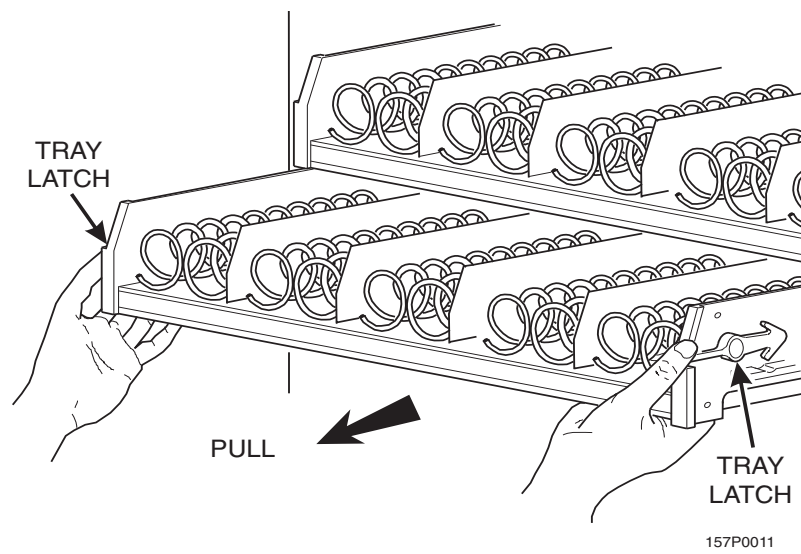

7. Continue pulling the tray forward for another inch. You will then be able to tilt the tray downward into the loading position as shown.

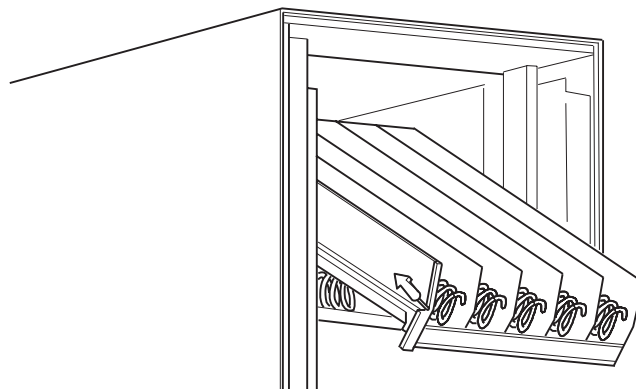

### NOTE

**When the cabinet door is not fully open, the bottom tray will rest on the delivery pan assembly. Handle the tray with care to avoid scratching the delivery pan assembly.**

### 1. Set up Trays to Vend Products

These instructions will guide you through setting up your trays for vending. You will be asked to determine if your tray can physically hold the products you intend to vend. If not, you will be directed to other procedures which will help you get them set up. Follow these nine steps for each tray in your machine:

1. Make sure the tray is in the loading position.
2. Is the column wide enough for the intended product? If so, proceed to the next step. Otherwise, set up your tray to vend wider products (see below, this page). When you're done, return to step 3 in this procedure.
3. Will the products fit between the spiral turns? If so, proceed to the next step. Otherwise, change the spiral.
4. Will the product pass under the tray immediately above? If so, proceed to the next step. Otherwise, reposition the tray and guides.
5. Will the product touch products on either side? If not, proceed to the next step. Otherwise, install a product spacer.
6. Load products in the tray.
7. Return the tray to the vending position.
8. Install the price rolls.
9. Install the selection ID numbers.

### 2. Set Up A Tray To Vend Wide Products

The following steps will help you configure your tray to vend wide products. When you have completed the procedures called out in each step, return to the next step in the procedure. When you are done with the entire wide product steps, return to the set-up procedures above.

1. Remove the tray from the merchandiser and place on a flat surface.
2. Based on the size of the product you want to vend, decide how many spiral positions it will occupy. Please remember that the leftmost spiral in the group **must** have an even ID number (0, 2, 4, etc.) For example, if a product is three spirals wide, the left spiral will be ID number 0, and the right spiral will be ID number 2. Be careful how wide you set up for, because really wide products could get hung up in the delivery door.
3. Remove the column dividers inside the group. In the example of three spiral positions, you would be removing the dividers between spiral ID numbers 0 and 1, and 1 and 2.
4. If your group only consists of 2 spirals, replace the rightmost motor with a spiral bearing and gear, and install a gear on the leftmost motor. Skip to step 8.
5. Remove all spirals in the group except the leftmost spiral.
6. Do one of the following:
  - a. If your group has an **ODD** number of spirals (3, 5, etc.) remove the harnesses from all motors in the group except the leftmost one. To the rightmost motor, connect the harness from the motor immediately to its left.
  - b. If your group has an **EVEN** number of spirals (4, 6, etc.) remove the harnesses from all motors **inside** the group (leave the harnesses connected to the leftmost and rightmost motors).

## Snack / Refreshment Center Setup and Operator's Guide

7. Install a spiral at the rightmost position in your group. Make sure it has the same product capacity and is opposite to the one in the leftmost position.
8. Return the tray to the merchandiser.
9. Electronically couple the motors as needed (see your *Programming Guide for information*).
10. Return to step 3 in the *Set Up Trays to Vend Products procedure*, above.

### 3. Removing a Tray

Study this procedure before you install a tray for the first time; while you are holding the tray you will not be able to see this area. Proceed as follows:

1. If your machine has tray latches, push with your palms. This releases the tray latches. Otherwise, skip to step 4.
2. Push down on the tray latches with your thumbs.
3. Pull the tray forward until you hear and feel the rear tray rollers drop into a cut-out in the top of the guide rail.

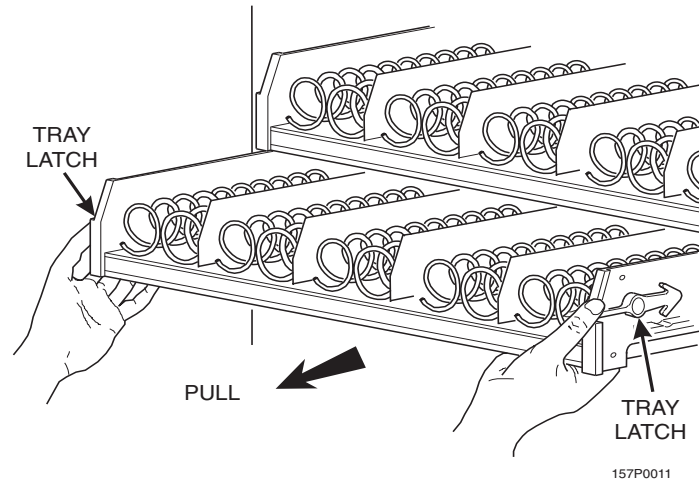

4. Lightly lift the front of the tray and pull the tray toward you until you hear and feel the rear tray rollers drop into a cut-out in the top of the guide rail.

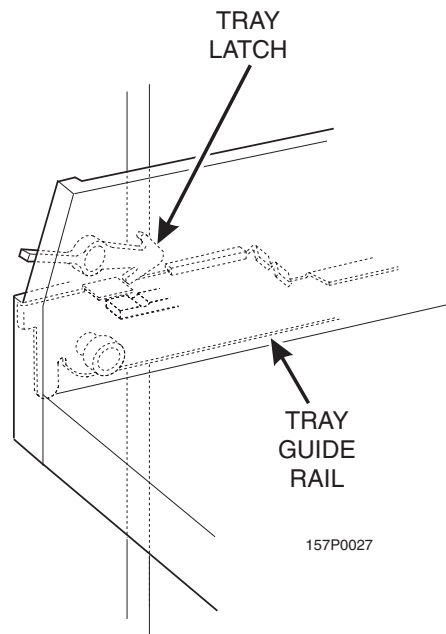

### 3. Removing a Tray (continued)

5. Unplug the tray wiring harness from the PC board mounted on the tray guide rail JUST ABOVE the tray you are removing.

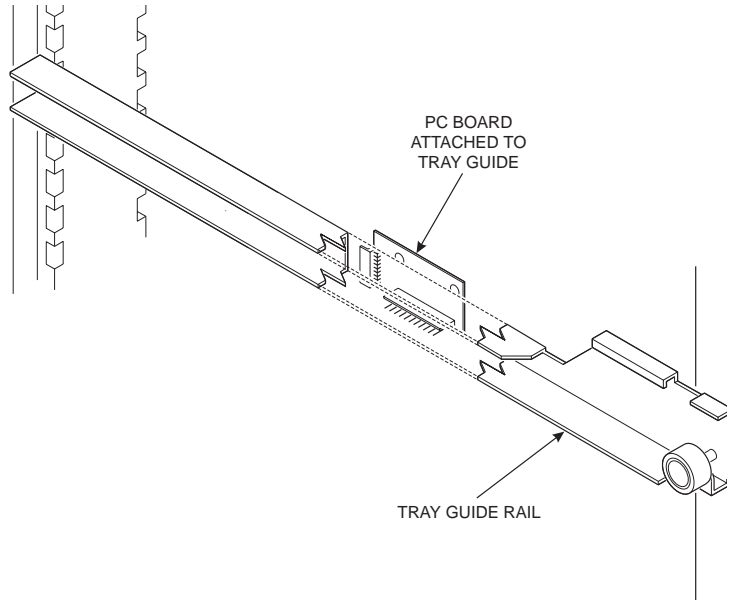

6. Lift up on the tray and slide it toward the back. No more than an inch should be needed.

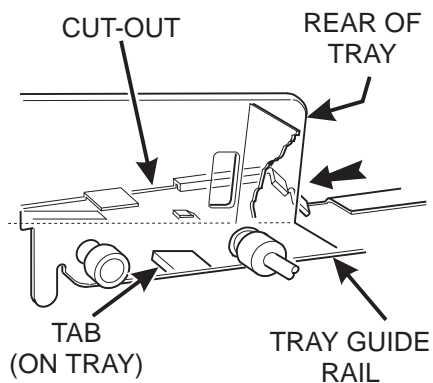
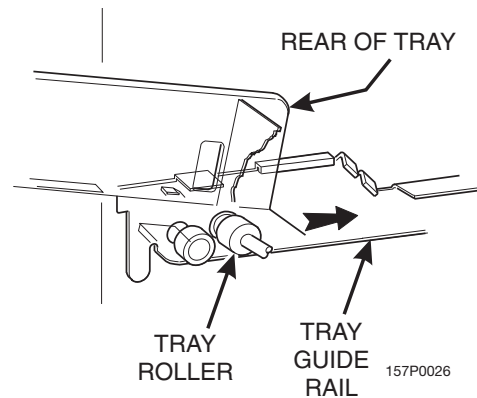

7. The tab near the back of the tray should align with the cut-out in the top of the guide rail as shown.
8. Lift the tray clear of the guide rail and out of the merchandiser.

#### CAUTION

When the cabinet door is not fully open, use extra care in removing the bottom tray. Failure to do so may result in damage to the tray or to the delivery pan assembly.

## 4. Removing and Installing Column Dividers

1. Push the column divider toward the back of the tray - ①.
2. Lift the column divider clear of the tray - ②.
3. Install the column divider in the reverse order of removal.

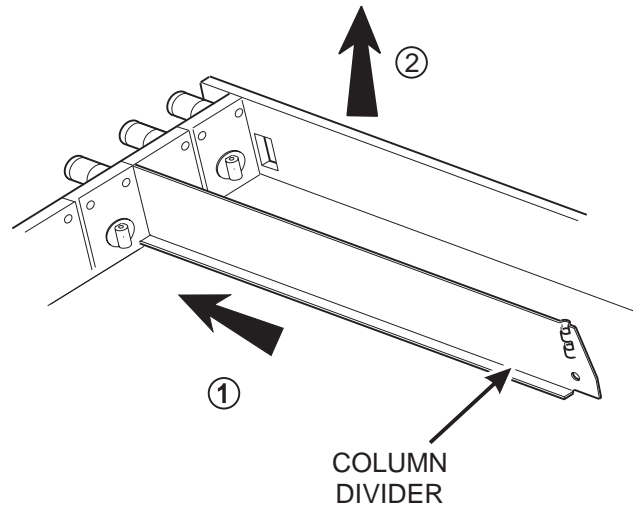

## 5. Operate a Tray Outside the Machine

Tray harness extension (P/N 1709017) is available from your National Vendors Parts department. The extension will enable you to remove the tray from the machine and still operate the motors and spirals. Connect it as shown:

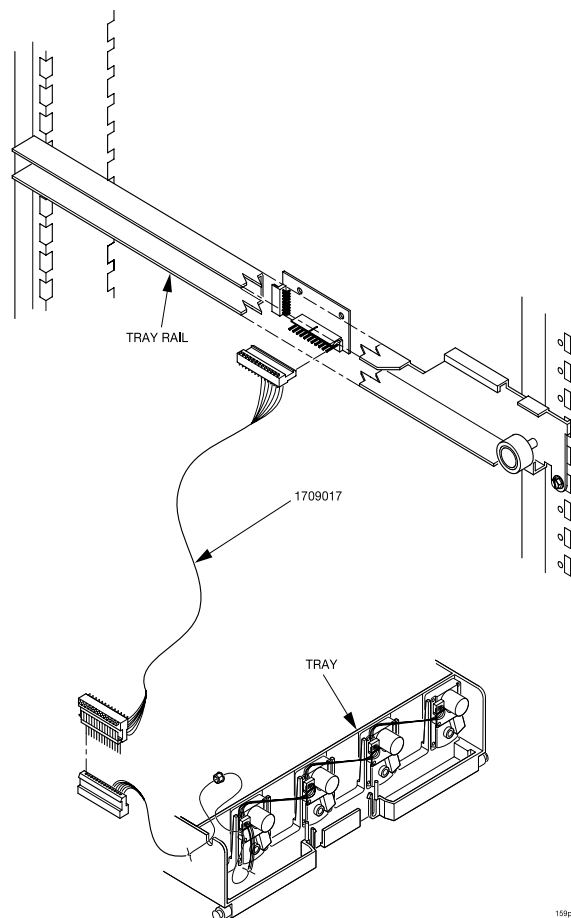

## **1. Replacing a Motor With a Spiral Bearing**

### **REMOVING A MOTOR:**

1. Disconnect the harness from the motor.  
(See **CONNECTING AND DISCONNECTING A MOTOR HARNESS**), *below*.
2. Remove the spiral. (See **REMOVING AND INSTALLING SPIRALS**).
3. Remove the spiral coupler. (See **REMOVING A SPIRAL COUPLER**).
4. Remove the motor. (See **REMOVING AND INSTALLING A SPIRAL MOTOR**).

### **INSTALLING A SPIRAL BEARING:**

1. Put the gear into position if required in this set-up as shown. (See **INSTALLING A GEAR**).
2. Install the spiral coupler. (See **INSTALLING A SPIRAL COUPLER**).

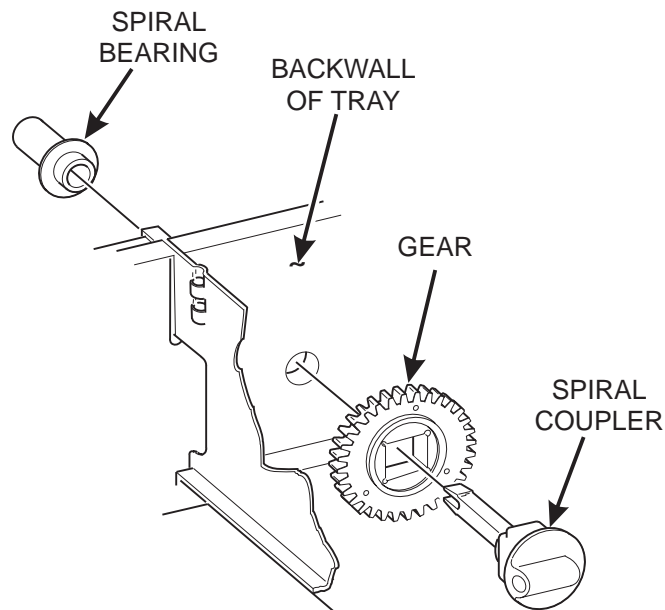

## **2. Connecting and Disconnecting a Motor Harness**

### **CAUTION**

**To avoid breaking the motor circuit board, hold the header on the circuit board whenever connecting or disconnecting a motor harness.**

### **DISCONNECTING A MOTOR HARNESS:**

1. Pull the harness connector away from the circuit board as shown.
2. Tuck the unused part of the harness out of the way in the trough at the back of the tray.

### **CONNECTING A MOTOR HARNESS:**

1. Locate the harness connector for the appropriate tray position.
2. Push the harness connector over the header pins on the motor circuit board as shown.

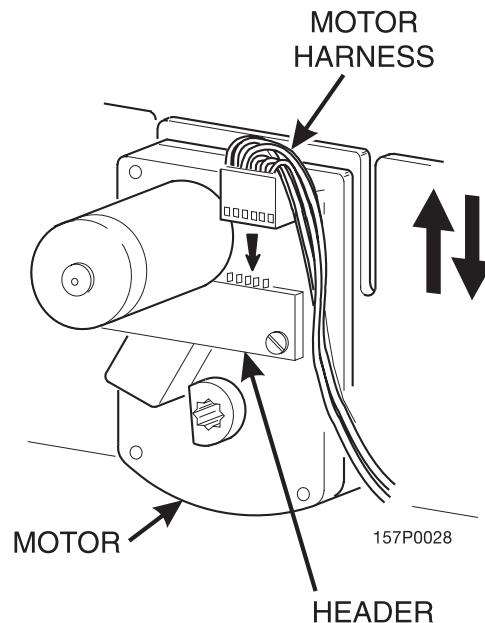

## 3. Removing and Installing Spirals

- All spirals are the same diameter:

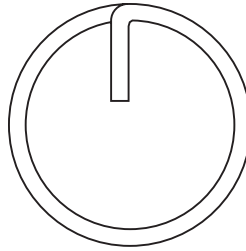

- There are two types of spirals:

**COUNTER-CLOCKWISE (left hand)**

**CLOCKWISE (right hand)**

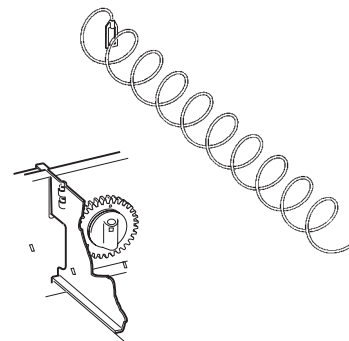
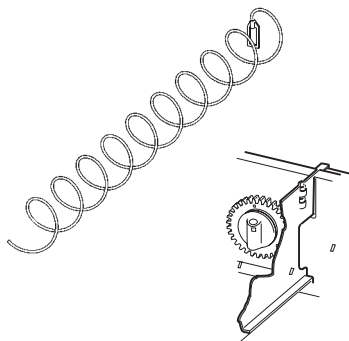

- Spirals are available in eight different capacities. Four of these are standard, and four are options.

ITEM CAPACITY OF SPIRAL	PART NUMBER		CLIP COLOR
	CLOCKWISE (RH)	COUNTER CLOCKWISE (LH)	
6 (Optional)	1477104	1477102	Purple
11 (Standard)	1477027	1477024	Blue
13 (Standard)	1477033	1477030	Yellow
15 (Standard)	1477039	1477036	Red
20 (Standard)	1477045	1477042	White
25 (Optional)	1477051	1477048	Green
30 (Optional)	1477057	1477054	Black
38 (Optional)	1477063	1477060	Orange

**3. Removing and Installing Spirals (continued)**

SPIRALS FOR MODELS 172, 173, 452, AND 453

ITEM CAPACITY OF SPIRAL	PART NUMBER		CLIP COLOR
	CLOCKWISE (RH)	COUNTER CLOCKWISE (LH)	
8	1707017	1707019	Grey
10	1707005	1707007	Blue
12	1707009	1707011	Yellow
14	1707013	1707015	Red
18	1707021	1707023	White

**TO REMOVE A SPIRAL:**

1. Pull forward on the retaining clip and remove the end of the spiral from the spiral coupler as shown.
2. Remove the spiral from the tray.

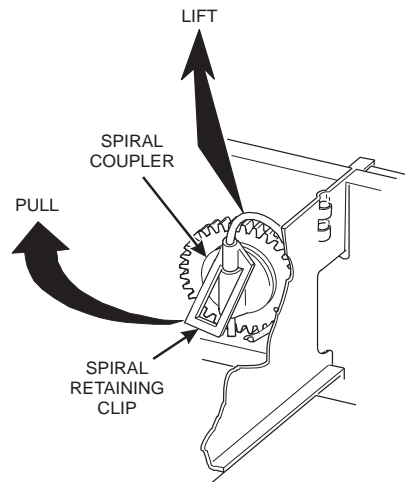

**TO INSTALL A SPIRAL:**

1. Pull the bottom of the retaining clip toward the front of the spiral.
2. Lower the spiral into the tray column and insert the end of the spiral into the spiral coupler as shown.
3. Release the retaining clip.

**SHOULD I USE A CLOCKWISE OR A COUNTERCLOCKWISE SPIRAL?**

1. The type of spiral used is determined by the column position it will occupy in the tray.
2. Refer to the figure below to find the correct spiral type.

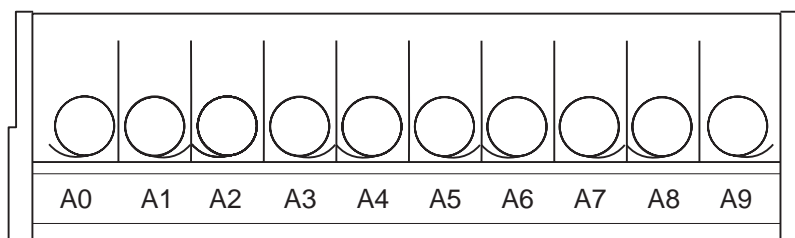

## **1. Removing a Spiral Coupler**

1. Pinch together the prongs on the end of the spiral coupler as shown.
2. Pull the coupler forward (in the direction of the arrow as shown)

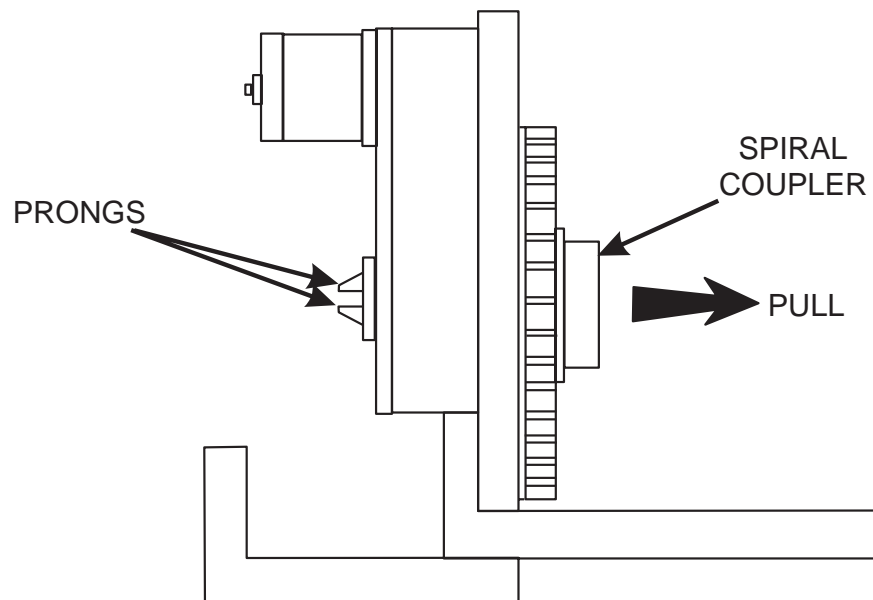

## **1. Removing and Installing a Spiral Motor**

### **REMOVING A SPIRAL MOTOR:**

**NOTE:**

**Some steps may already be completed.**

1. Remove the tray. (See **REMOVING A TRAY**).
2. Disconnect the motor harness.  
(See **CONNECTING AND DISCONNECTING A MOTOR HARNESS**).
3. Remove the spiral.  
(See **REMOVING AND INSTALLING SPIRALS**).
4. Remove the spiral coupler.  
( See **REMOVING A SPIRAL COUPLER**).
5. Lift the motor clear of the tray.
6. Return the tray to the merchandiser.  
(See **INSTALLING A TRAY IN THE MERCHANDISER**).

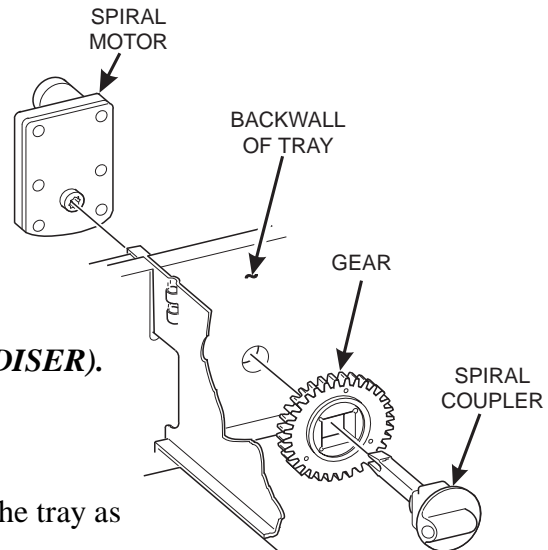

### **INSTALLING A SPIRAL MOTOR:**

1. Remove the tray. (See **REMOVING A TRAY**).
2. Place the motor in the correct position at the rear of the tray as shown.
3. Place a gear in position if required by this set-up.  
(See **INSTALLING A GEAR**).
4. Install a spiral coupler in the proper orientation. (See **INSTALLING A SPIRAL COUPLER**).
5. Connect the motor harness.  
(See **CONNECTING AND DISCONNECTING A MOTOR HARNESS**).
6. Return the tray to the merchandiser.  
( See **INSTALLING A TRAY IN THE MERCHANDISER**).

## 2. Installing a Gear

### WHEN ARE GEARS USED?

- Gears are used to mechanically couple the spirals together.
- This happens whenever you have two spirals and only one motor for vending a selection.

### WHERE ARE THE GEARS PLACED?

- The gear is placed between the back of the tray and the spiral coupler.

### HOW IS THE GEAR ORIENTED?

- There are two possible orientations for the gear:

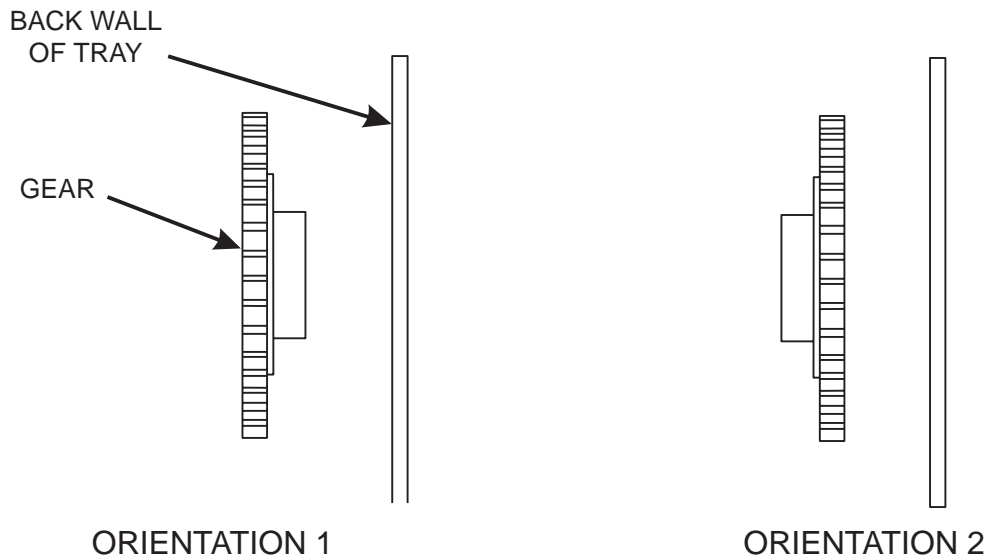

- There are two rules to follow when orienting gears:

**RULE 1-The gears for selections next to each other cannot use the same orientation.**

**RULE 2-All gears for a single selection must use the same orientation.**

### **3. Installing a Spiral Coupler**

1. Place the gear in position if one is required for this set-up. (See *INSTALLING A GEAR*).

#### **WHEN USED WITH A MOTOR:**

2. Hold the motor in place and push the spiral coupler through the motor gear box until it clicks into position. Be sure the spiral couplers are oriented as shown below.

#### **NOTE**

**The motor output shaft opening contains eight facets to allow the spiral coupler to be installed in any one of eight positions.**

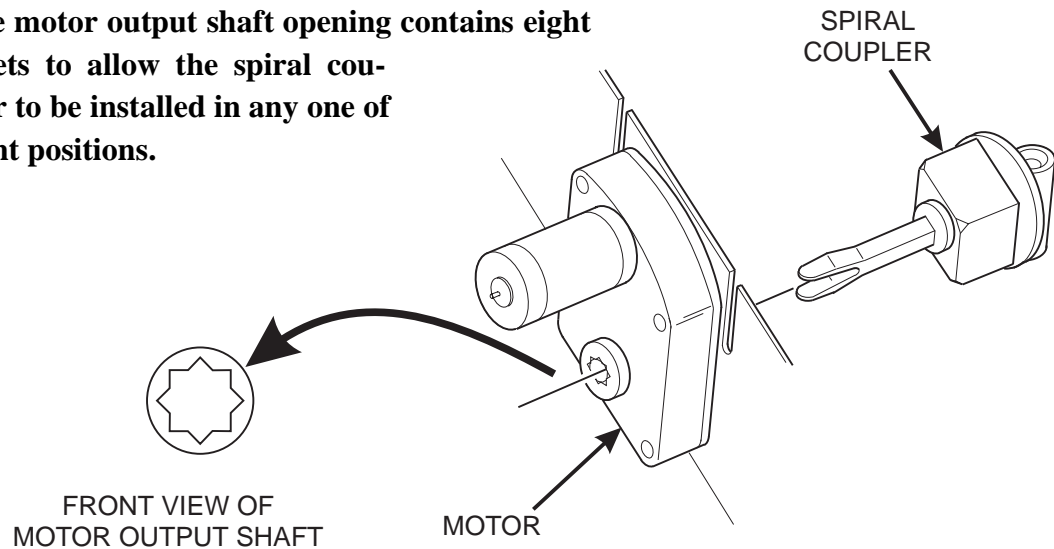

#### **SPIRAL COUPLER ORIENTATION**

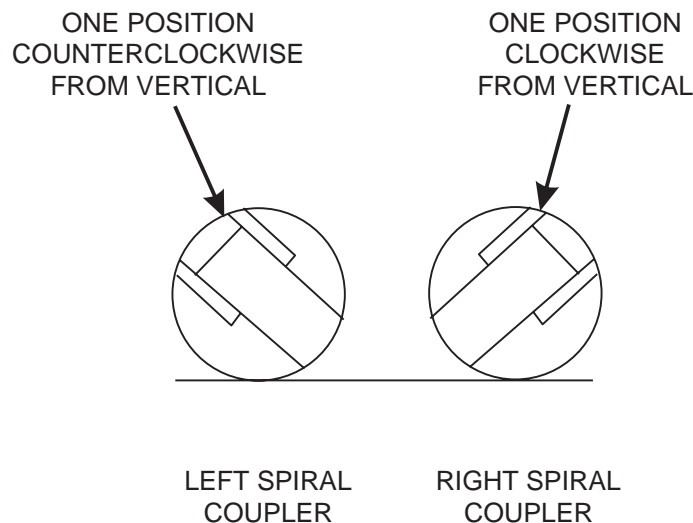

AS VIEWED FROM FRONT OF TRAY

### **3. Installing a Spiral Coupler (continued)**

**WHEN USED WITH A COUPLER BEARING:**

3. Hold the coupler bearing in place and push the spiral coupler through the bearing until the coupler clicks into position. Be sure the coupler is in the proper orientation as shown.

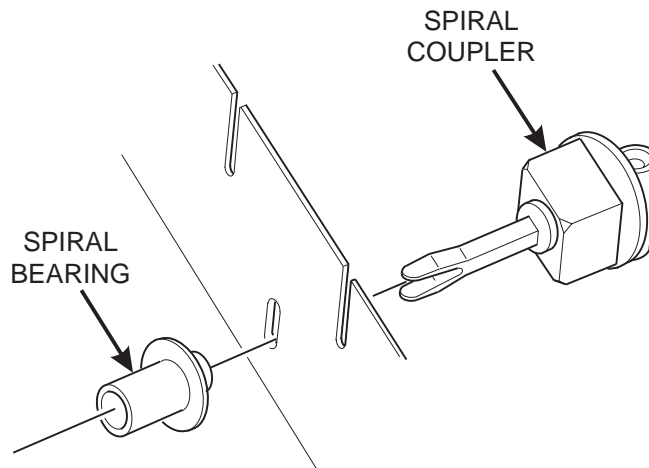

## 4. Moving a Tray Up or Down

This merchandiser can be adjusted to vend taller products. Some guidelines must be followed:

- Keep in mind that when you increase the product height available to a tray by lowering it, you will be decreasing the product height available to the tray below.
- If a tray is in the lowest position, the tray below it should not be in the highest position.
- If a tray is in the highest position, the tray above it should not be in the lowest position.
- You will need to experiment with various tray positions to get the best results for your products.

### CAUTION:

**The trays in a model 764 and 765 merchandiser should not be positioned over an open air discharge vent.**

### NOTE:

**Tray movement is limited because the tray harness will limit the amount of travel available to the tray guide rails.**

Proceed as follows:

1. Remove the tray from the merchandiser. (See **REMOVING A TRAY**).
2. Remove the screw that secures the right tray guide rail to the front guide mounting channel as shown.
3. Tap up on the guide rail and unseat the guide rail tabs from the channel slots.
4. Pull the guide rail away from the front and rear guide mounting channels.
5. Move the guide rail to the desired position.
6. Insert the guide rail tabs into the mounting CVchannel slots as shown.
7. Tap down on the guide rail to seat the tabs in the channel slots.
8. Replace the screw that secures the guide rail to the front guide mounting channel.
9. Repeat steps 2 through 8 for the left guide rail.
10. Return the tray to the merchandiser.  
( See **INSTALLING A TRAY IN THE MERCHANDISER**).
11. Load products into the trays, and perform test vends. Make sure the trays don't interfere with the products you are vending, and that all products vend properly.

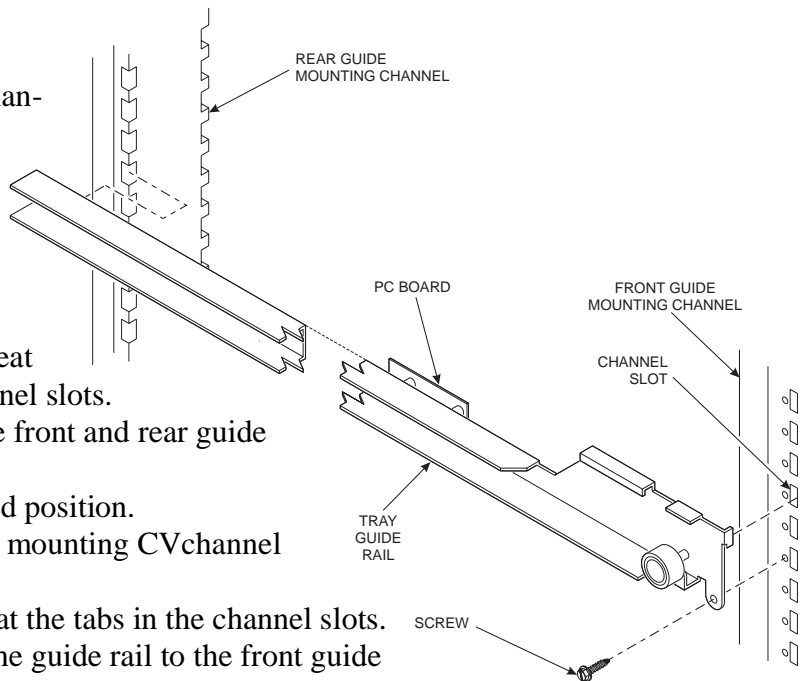

## 5. Installing a Tray in the Merchandiser

- Study this procedure before you install a tray for the first time; while you are holding the tray you will not be able to see this area. Proceed as follows:

1. Insert the tray so that the tray rollers pass over the tray guide rollers.

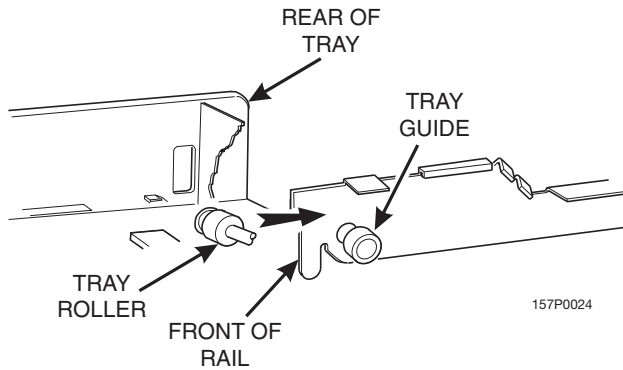

2. Bring the tray roller to rest on the tray guide.

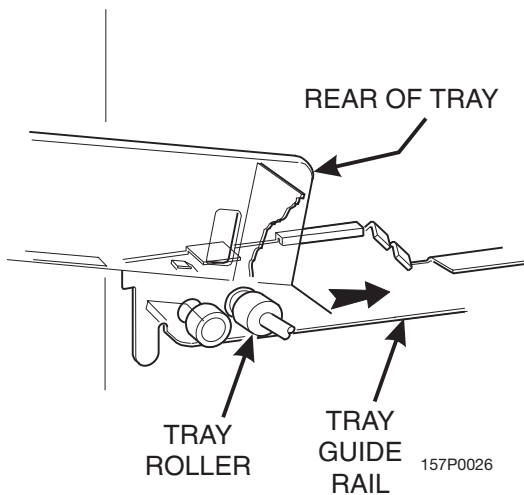

3. Tilt the tray upward.
4. Connect the tray wiring harness to the PC board mounted to the guide rail JUST ABOVE the tray you are installing.

5. Hold the tray up while pushing it toward the rear. Stop when the tab on the tray aligns with the opening in the tray guide.

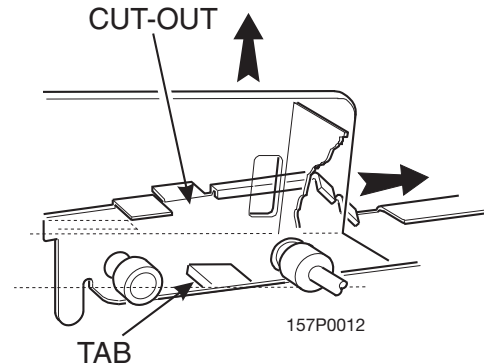

6. Lower the tray until it rests on the tray guide roller. Push the tray in all the way.
7. The tray latch will fall into the locking position.

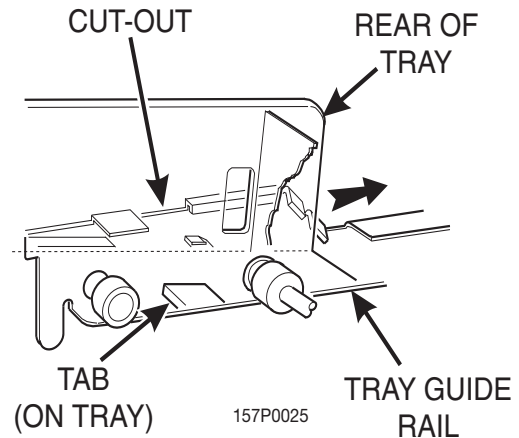

## **10. Installing and Removing a Product Spacer**

### **INSTALLING A PRODUCT SPACER:**

The product spacer will keep a tall, narrow product upright.

Shown at right are spacers and column dividers on both deep and shallow trays.

Insert the product spacer onto the column divider as shown.

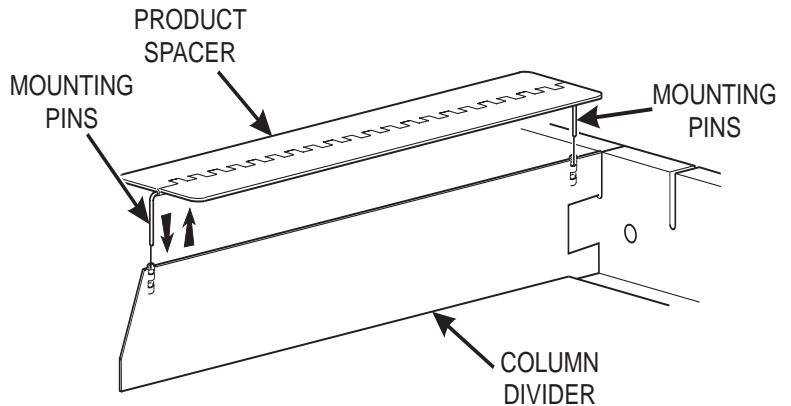

### **ADJUSTING A PRODUCT SPACER:**

With product loaded in the tray, rotate the product spacer up or down to keep the product upright as shown.

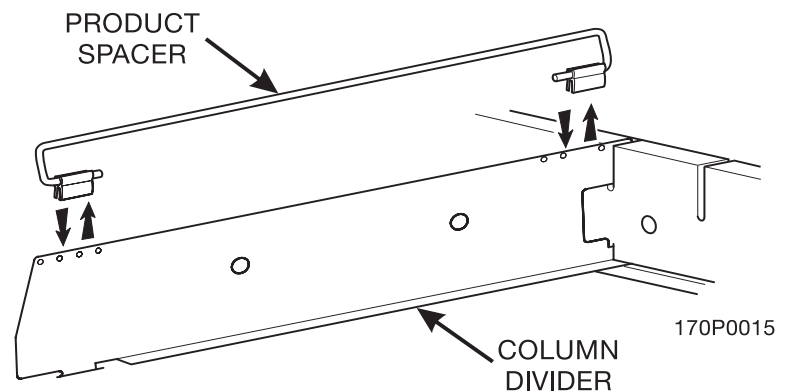

### **REMOVING A PRODUCT SPACER:**

Pull the product spacer mounting pins from the column divider.

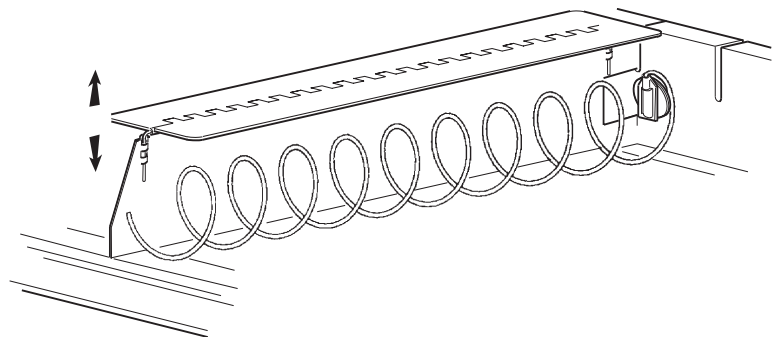

# 1. Load Trays With Product

## SPIRAL CAPACITY COLOR CODES

SPIRAL CAPACITY	SPIRAL COUPLER COLOR	SPIRAL CAPACITY	SPIRAL COUPLER COLOR
6	Purple	20	White
11	Blue	25	Green
13	Yellow	30	Black
15	Red	38	Orange

The color of the spiral coupler (the little plastic tab attached to the rear of the spiral) will tell you how many products will fit in the spiral. (See table at left).

### Spiral Capacity Color Codes Models 172, 177, 173, 452, 457, and 458

SPIRAL CAPACITY	SPIRAL COUPLER COLOR
8	Grey
10	Blue
12	Yellow
14	Red
18	White

**NOTE:**

**Another way to determine spiral capacity is to count the spaces in the spiral!**

### **LOADING A TRAY WITH PRODUCTS IN GENERAL:**

- (See *PRODUCT PUSHER USAGE*) for spirals with capacity of 11, 13, or 15.
- (See *SPIRAL WALL RETAINER USAGE*) for spirals with capacity of 20, 25, 30, or 38.
- Begin loading products at the front of the tray and work toward the back. Position the product so the package rests on the tray. **DO NOT** force a product into a spiral.
- If the fit is too tight or too loose, change the spiral size. (See *REMOVING AND INSTALLING A SPIRAL*).
- Be sure there are no empty positions between products in each spiral.

### **SPECIAL CONSIDERATIONS:**

- Bagged Products - Position package upright, then push the tops slightly toward the rear of the tray. Also, (see *PRODUCT PUSHER USAGE*).
- Thin Packages - Position the package upright. Also, (see *SPIRAL WALL RETAINER USAGE*).
- KitKat - The two right-most columns of the candy tray are designed to accept the KitKat candy bar.
- Chilled Candy - Use the lowest trays for candy that is to be chilled.

### **WARNING**

**This merchandiser does not have a health control circuit. It is not approved for the vending of perishable food items.**

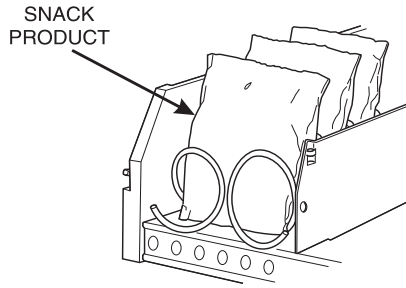

**CORRECT LOADING OF SNACKS**

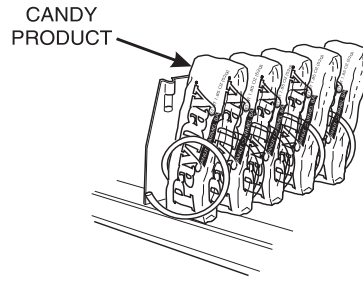

**CORRECT LOADING OF CANDY** 157P0035

## A. Load Trays With Product (continued)

### SPIRAL WALL RETAINER USAGE:

A spiral wall retainer serves to compress the spiral and make it act like a spring to more forcefully eject a product. Do some test vends and use a spiral wall retainer when a product does not readily leave the spiral.

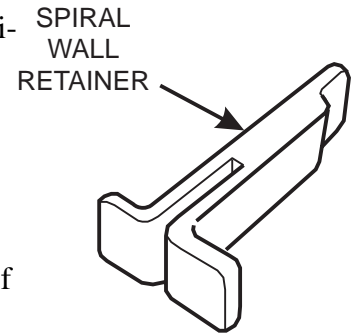

- Use a spiral wall retainer in the following cases:
  - The spiral has a capacity of 20, 25, 30, or 38.
  - The product is thin.
  - The product is on a candy tray.
- The spiral wall retainer can also be used with other spirals and types of products.
- The spiral wall retainer is installed near the front of the column divider. There are two ways to install the spiral wall retainer.

<b>RETAINER ORIENTATION</b>		
	<b>A</b>	<b>B</b>
<b>COLUMN DIVIDER BETWEEN THESE POSITIONS</b>	0 and 1	1 and 2
	2 and 3	3 and 4
	4 and 5	5 and 6
	6 and 7	7 and 8
	8 and 9	

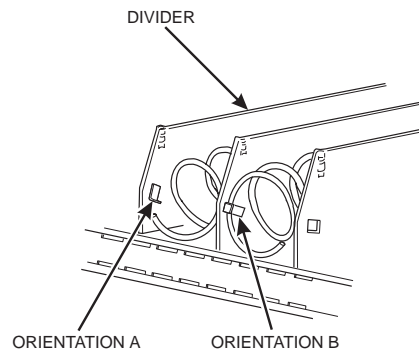

- To install a spiral wall retainer, insert the retainer in the square slot near the front of the column divider.
- The spiral wall retainer must be removed in two cases:
  - A KitKat bar loaded into either of the two right hand positions of a tray will not clear the retainer on the column divider between the two positions.
  - A product pusher will catch on a retainer in *ORIENTATION A*.

## B. Load Trays With Product (continued)

**PRODUCT PUSHER USAGE:** The product pusher will give the top of a product an extra tilt to help it fall into the delivery pan.

Use a product pusher in the following cases:

- The spiral has a capacity of 15, 13, or 11.
- The package is non-rigid like bagged peanuts

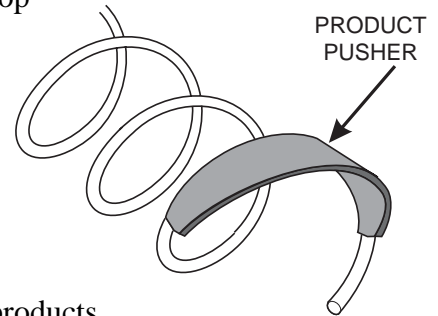

The product pusher can also be used with other spiral and types of products.

A bag of product pushers has been shipped with the merchandiser. Additional product pushers are available from the National Vendors' parts department. To use a product pusher, snap it on the spiral as shown. You can adjust the product pusher by moving it around on the spiral to achieve the best vending results.

### **PREPARING THE MERCHANDISER FOR VENDING "LUNCH BUCKET":**

Because of the weight and shape of the package, National Vendors recommends that this product be vended only from the bottom tray.

To vend this product, two adjacent positions must be coupled together.

(See *INSTALLING A GEAR, for mechanical coupling directions, or see the Programming Guide for electrical coupling directions*).

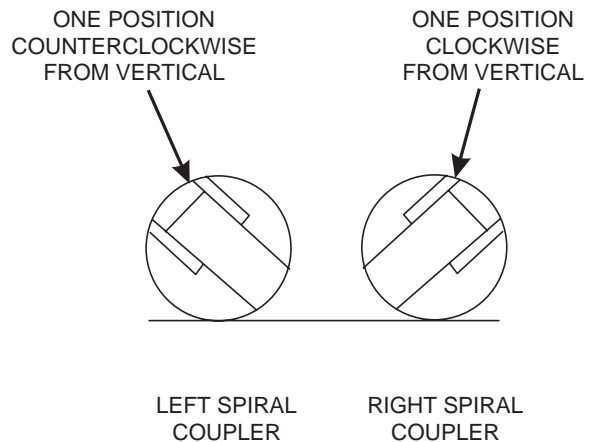

AS VIEWED FROM FRONT OF TRAY

The left spiral coupler should be installed one position counterclockwise from the vertical position.

The right spiral coupler should be installed one position clockwise from the vertical position.

Replace the current spirals with six-count spirals. These are available from the National Vendors parts department. (See *REMOVING AND INSTALLING SPIRALS*). A pad can be installed in the bottom of the delivery pan to quiet and cushion product delivery. This part is available from the National Vendors parts department. Load "Lunch Bucket" products as shown.



Proper Loading of "Lunch Bucket"

**C. Loading a Tray With Product (continued)**

**PREPARING THE MERCHANDISER FOR VENDING "TOP SHELF":**

National Vendors recommends that this product be vended from a candy tray.  
 Move the tray so the package can be loaded standing on its left or right edge.  
 ( See *MOVING A TRAY UP OR DOWN*).

The following steps must be completed for three adjacent positions on the tray:

**NOTE**

**The left-most position in the group of three must be an even numbered position.**

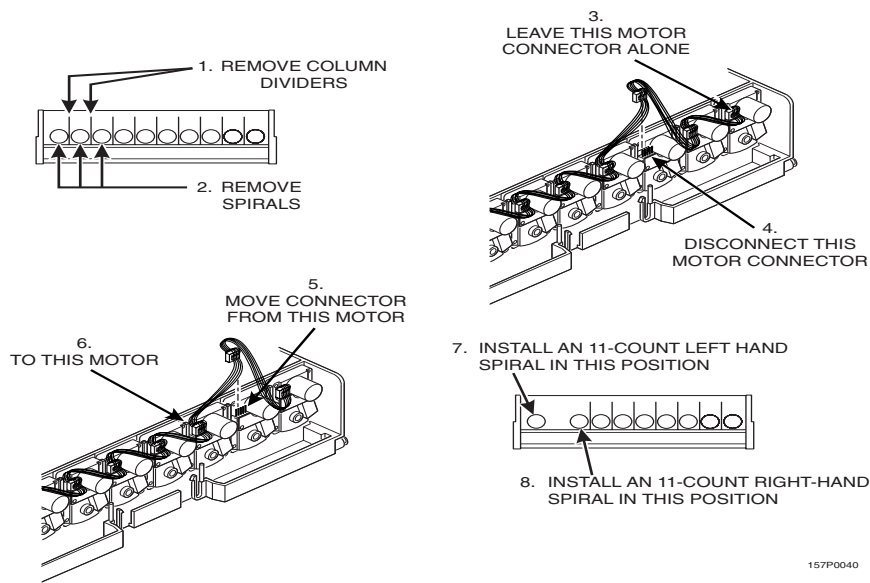

157P0040

**NOTE**

**If the motor harness you disconnected in step 5 does not reach, use the motor skip harness, P/N 1599024, available from the National Vendors Parts Department.**

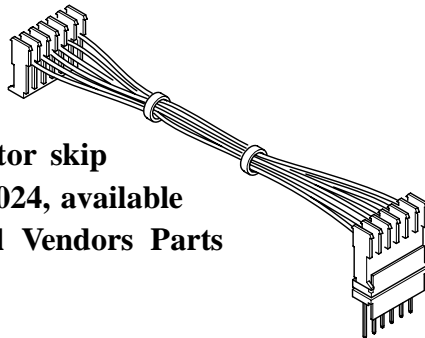

167p0024

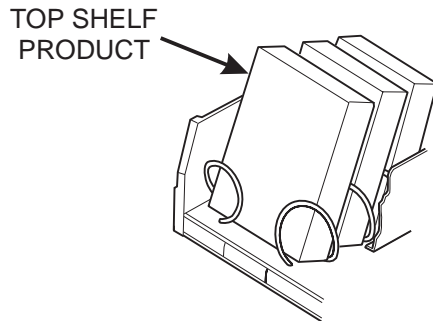

Couple the left motor to the right motor. (See the Programming Guide).

Load the "Top Shelf" products as shown.

## **1. Return the Trays to the Vending Position**

1. Lift the tray until it is parallel to the floor as shown.

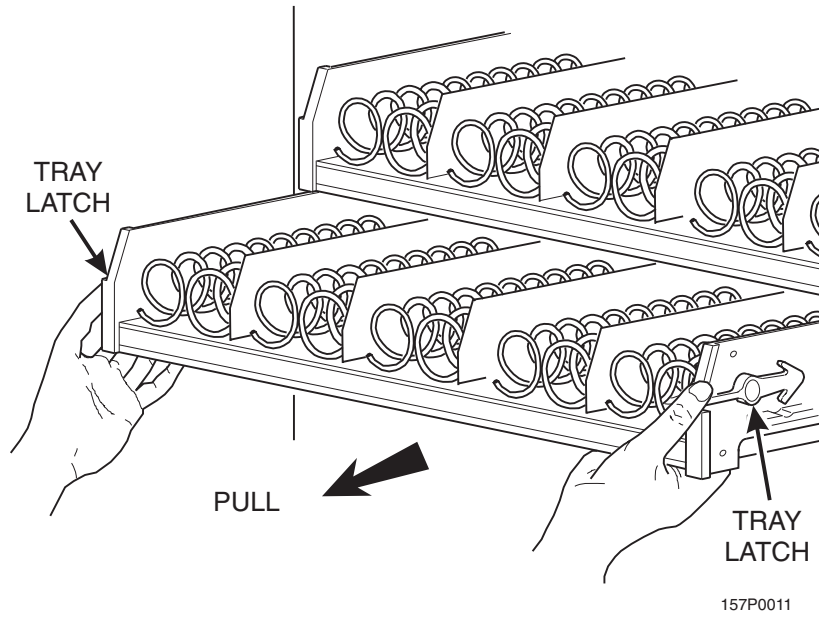

2. Push the tray toward the back of the cabinet. The tray latches on the sides of the tray will lock into position.

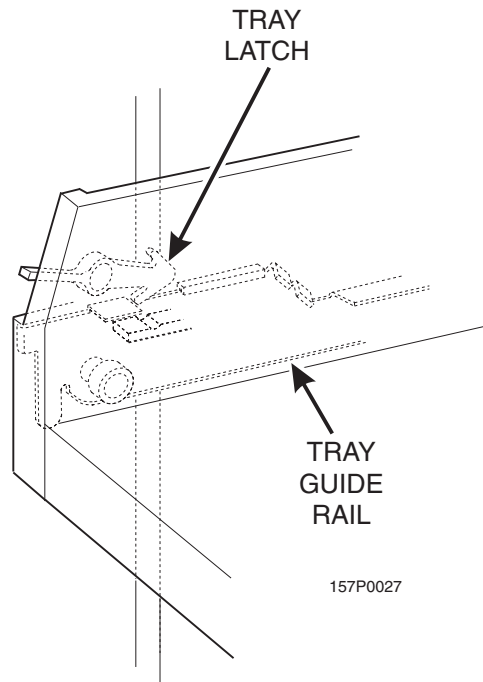

## 2. Install and Set Price Labels

- Price rolls are printed on coiled-up strips as shown in this example. (The dollar and cents rolls are factory installed.) If you use another type of currency, you will find the appropriate price rolls in the plastic bag that contained this manual.
- There are two types of price rolls installed:
  - Dollar roll - 1 to 12, increments of 1
  - Cents roll - 00 to 95, increments of 05
- Remove the price rolls as required, and install the appropriate one(s) for your currency.

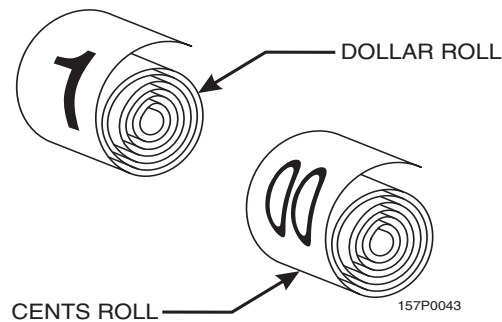

### **INSTALLING PRICE LABELS:**

- There are three pairs of slots in the front of the can unit for each position. Install per this example:
  1. Insert the dollar roll in the left-most pair of slots as shown if the price is \$1.00 or more.
  2. Insert the cents roll in the center pair of slots as shown.
  3. The low-number end of the roll goes in the top slot and the high-number end of the roll goes in the bottom slot.

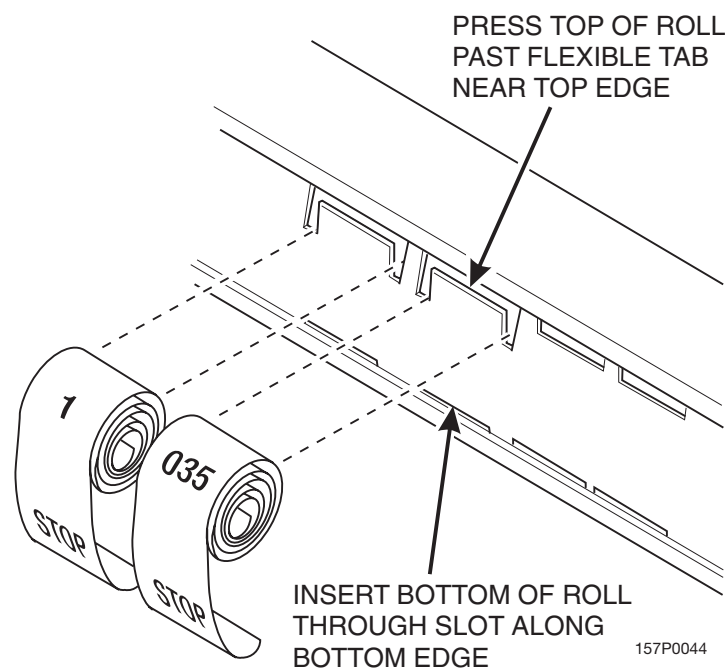

## **2. Install and Set Price Labels (continued)**

### **ADJUSTING THE PRICE ROLL:**

You can set selection prices within the following range:

Minimum price	\$ .00
Maximum price	\$12.95
Increment	\$.05

1. Use your thumb as shown to move each price roll up or down as needed to set the desired price.

### **NOTE**

**You will see the word STOP near either end of the roll.**

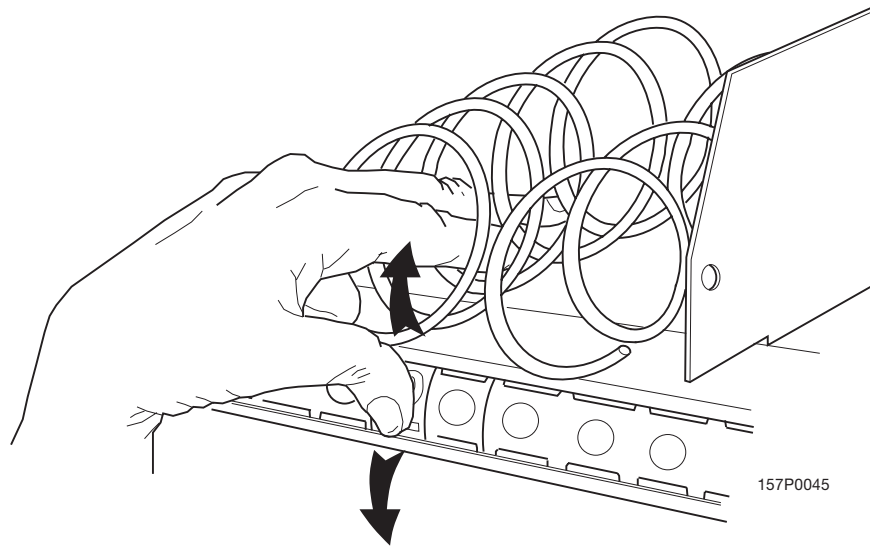

### **3. Install Selection ID Labels**

Selection ID numbers are printed on clear plastic sheets. You will find these in the plastic bag that contained this manual. You will need to separate them along the scored lines between the selections. **BE CAREFUL** when doing this, because it is easy to split the labels.

#### **INSTALLING SELECTION ID NUMBERS:**

1. Press together the two long edges of the selection ID label.
2. Snap the selection ID label into position on the front of the tray as shown.

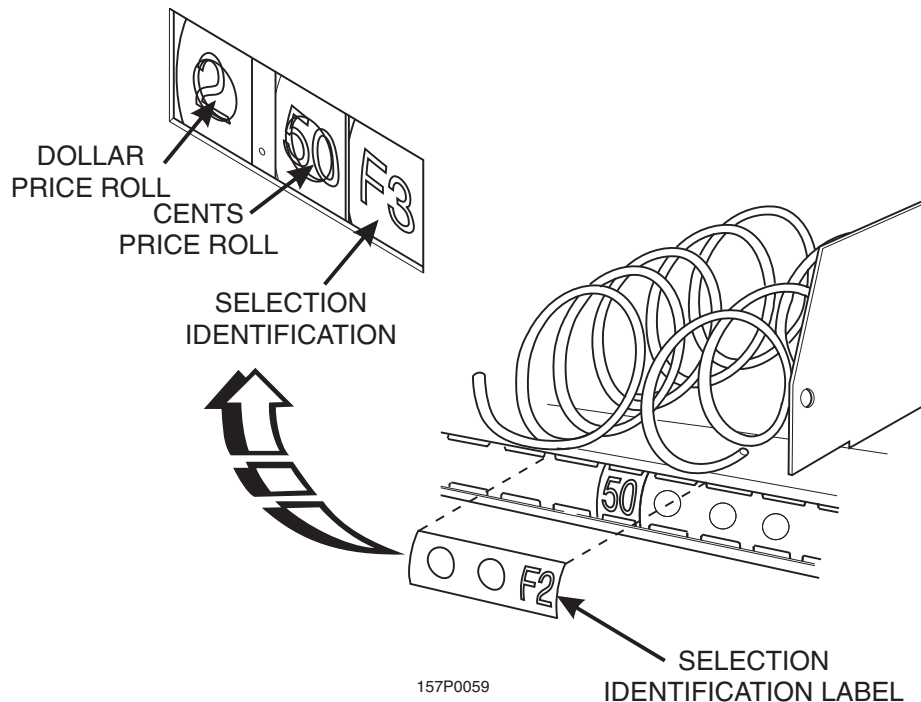

## 3. Install Selection ID Labels (continued)

**WHICH ID LABEL GOES WITH WHICH SELECTION?**

See the figures below for snack and candy tray positions.

**Motor Position**

<b>TOP TRAY</b>	TRAY A	A0	A1	A2	A3	A4	A5	A6	A7	A8	A9
	TRAY B	B0	B1	B2	B3	B4	B5	B6	B7	B8	B9
<b>BOTTOM TRAY</b>	TRAY C	C0	C1	C2	C3	C4	C5	C6	C7	C8	C9

**NOTE**

**This example shows a 3-tray merchandiser. Some merchandisers can have up to 6 trays.**

EXAMPLE OF A BASIC SNACK TRAY ID LABEL TO USE

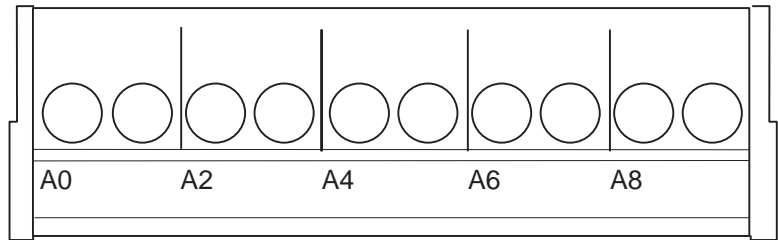

EXAMPLE OF A BASIC CANDY TRAY ID LABEL TO USE

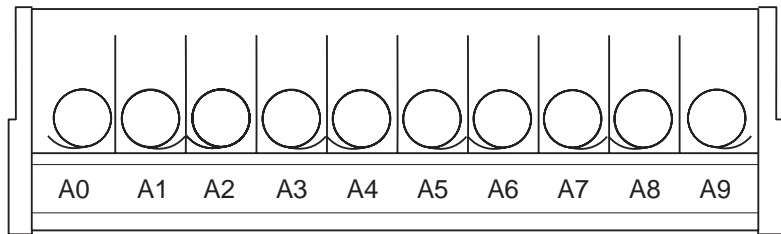

# Set Up The Gum and Mint Unit

## 1. Install Price Labels

The column ID labels have already been attached to the delivery door, and a set of self-adhesive price labels are in the plastic bag that contained this manual.

1. Stick the desired price label next to the column ID number as shown.

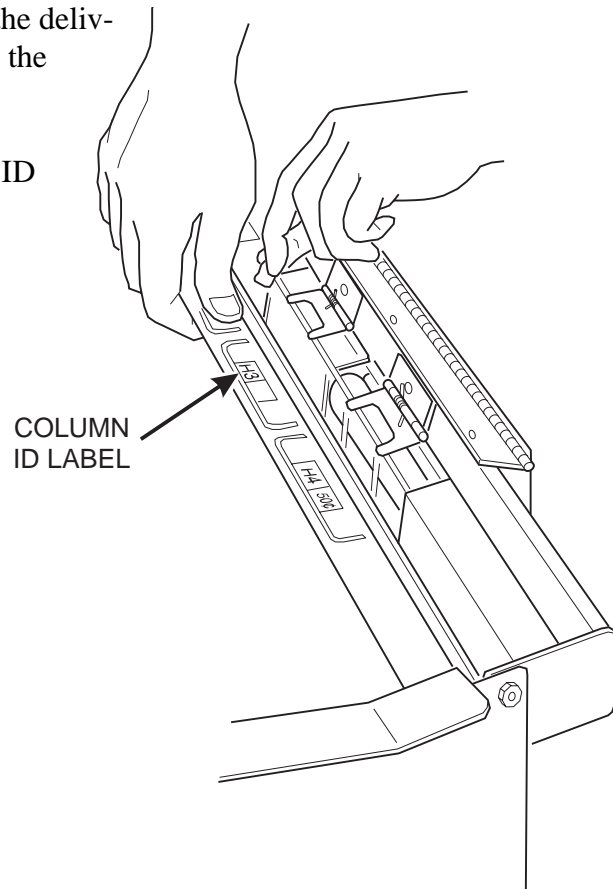

## 2. Put the Gum and Mint Dispenser in the Loading Position

The gum and mint assembly is hinged to the delivery pan assembly and is held in the vending position by two magnets. The gum and mint assembly is held in the loading position by a hook and a loop. One end of the hook is attached to the right side of the door. The loop is mounted on the right side of the gum and mint assembly.

1. Use the loop as a handle and raise the gum and mint magazine with your left hand. With your right hand, move the free end of the hook so it catches the loop. This will hold the magazine while you are loading it with product, as shown.

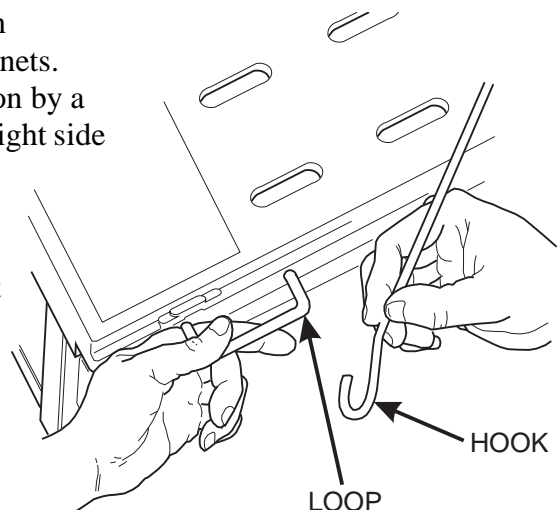

### 3. Load the Gum and Mint Dispenser With Product

1. The gum and mint assembly lid is held closed by two magnets. Open the lid toward the inside of the merchandiser door.

#### WARNING

Keep your hand on the product pusher until it is locked in place. Failure to do so may result in personal injury or in damage to the dispenser.

2. Move the product pusher into the loading position:
  - a. Pull back on the pusher.
  - b. Pull down on the pusher and lock the front glide into position.
3. Load the product:
  - a. Push the product forward.
  - b. Be sure the last item is completely under the product retaining clip.
4. Move the product pusher into the dispensing position:
  - a. Pull the product pusher down to unlock the front guide.
  - b. Slide the product pusher toward the product.

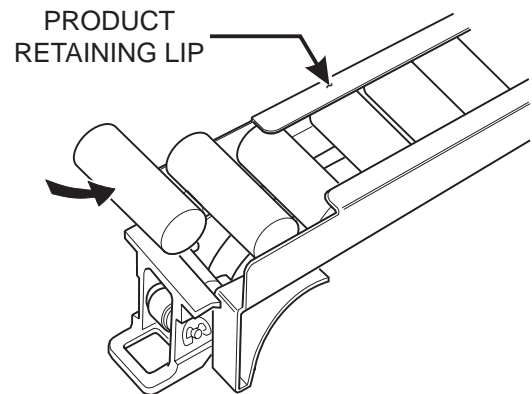
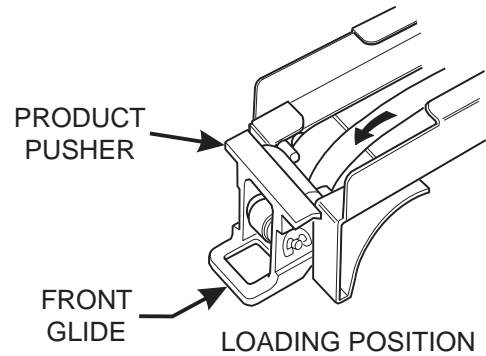

#### WARNING

Keep your hand on the product pusher until it comes to rest behind the last item in the column. Failure to do so may result in personal injury or in damage to the dispenser.

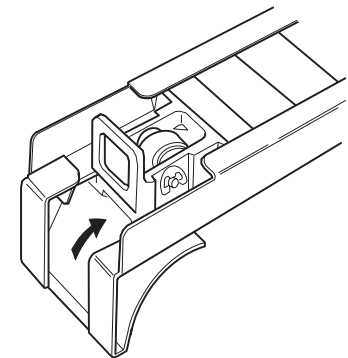

## **4. Return the Gum and Mint Dispenser to the Vending Position**

1. Make sure all product pushers are in the vending position.
2. Close the gum and mint assembly lid.
3. Hold the loop on the right side of the magazine with your left hand. Release the hook with your right hand and lower the magazine.
4. Continue to hold the loop until the magazine has been fully lowered.
5. Pivot the gum and mint assembly back to the vending position.

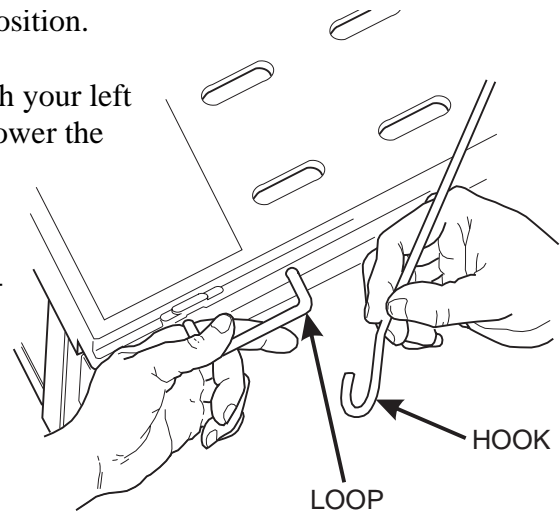

## **5. Removing and Installing Column Reducers**

The two left-most vending columns (as seen from the loading side) can be adjusted for two different widths.

When a column reducer is in place, the width of the column will be  $31/16$  inches.

When a column reducer is removed, the width of the column will be  $37/8$  inches.

### **TO REMOVE A COLUMN REDUCER:**

1. Pull the reducer away from the cabinet door to disengage the locking tabs.
2. Lift up to remove the reducer from the gum and mint assembly.

### **TO INSTALL A COLUMN REDUCER:**

1. Place the reducer on the gum and mint dispenser so the locking tabs are in the slots.
2. Push the reducer toward the cabinet door to lock the reducer in place.

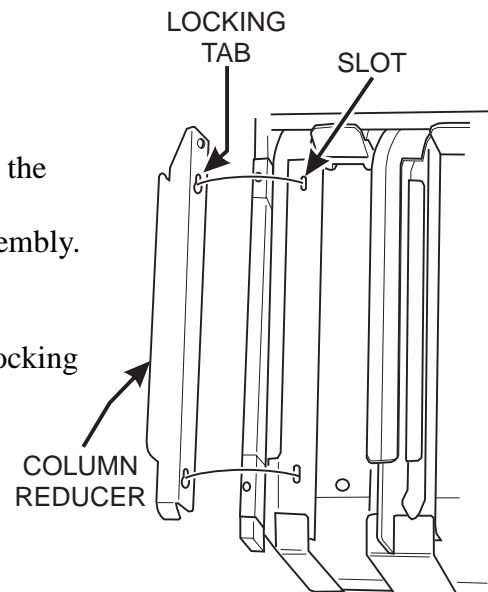

# Final Installation

Move the merchandiser to its *final position*:

- You can position this merchandiser anywhere in a bank of machines. It can even be placed on an end flush against a side wall.
- The 167 and 168 merchandisers should be located at least one inch away from the back wall.
- The 764, 765, 784, 787, 797, and 798 merchandisers should be placed at least six inches away from the back wall. This will provide adequate air circulation for the refrigeration unit.
- The 764, 765, 797, and 798 merchandisers will operate more efficiently when placed in a shaded location.
- There should be enough room in front of the merchandiser for the door to move freely.

## WARNING

**This machine is only rated for installation in an indoor location.**

## 1. Level the Merchandiser

1. Using a spirit level, adjust the legs until the cabinet is level from side to side and front to back.

### NOTE

**A slight slope from front to back will improve the draining of condensate from merchandisers with refrigerating units. When the merchandiser is part of a bank of machines, level it in reference to the other machines. After leveling is complete, check that the door operates easily.**

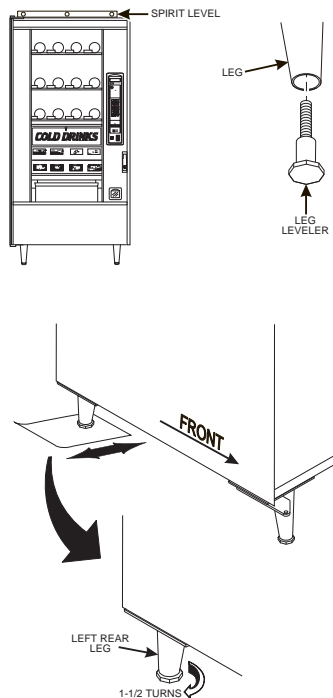

# Refrigeration Modules

Complete the setup of chilled snack features (models 764, and 789):

## 1. Connect a Refrigeration Module to an External Drain (Optional)

### METHOD 1:

1. Remove the condensate drain tube from the refrigeration module.
2. Connect a new drain tube to the refrigeration module housing.
3. Route the new tube to an external drain or to an overflow bucket.

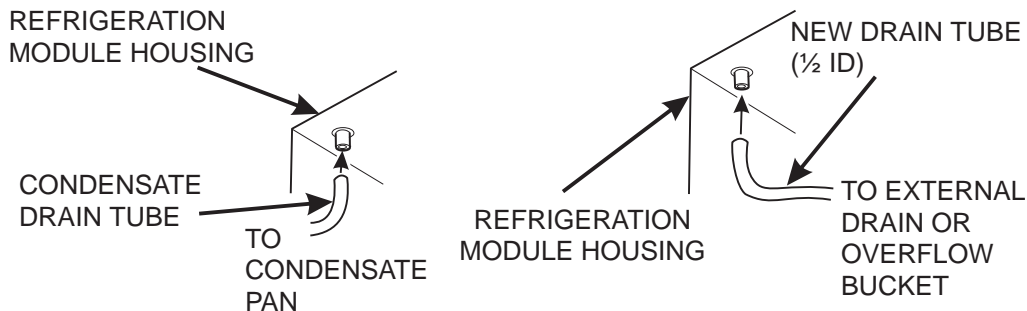

METHOD 1

### METHOD 2:

1. Connect a drain tube to the condensate pan.
2. Route the drain tube to an external drain or to an overflow bucket.

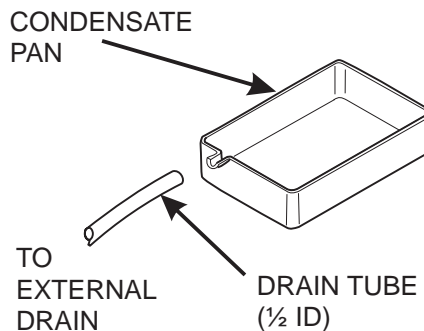

METHOD 2

## **2. Adjust the Air Discharge and Return Vents (Chiller Only)**

The air discharge and return vents are located in the right front and rear side wall. The vents are adjusted by loosening the screw and sliding the air duct shutter up or down as required. With the shutter all the way up, the vent is fully open. The vent is closed when the shutter is all the way down. Ideally, the temperature at the top tray should be the same as that at the bottom tray. Using a thermometer to monitor temperature, adjust the air discharge and return vents until the temperatures are as close together as possible.

### **CAUTION**

**Do not close off all discharge vents.  
Doing so can damage the refrigeration  
unit.**

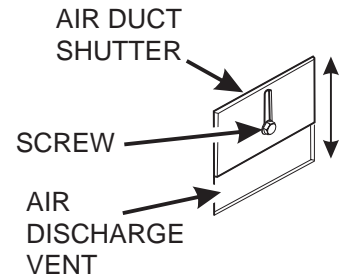

## 1. Install the Base Plate

Refer to the figure below while completing the following procedures:

### WARNING

**Do not move the cabinet while the hex head screws and/or carriage bolts are loosened. The cabinet would become unstable and likely to tip and cause injury.**

1. Remove the waste pail and the grounds pail from the merchandiser (refreshment center only).
2. Remove the floor liner from the merchandiser (refreshment center only).
3. Remove the two caps as shown.
4. Loosen the left leg assembly carriage bolts and nuts to allow mounting a base plate bracket.
5. Secure one of the base plate brackets to the leg assembly using the two carriage bolts. Tighten the carriage bolts and nuts.
6. Loosen the right leg assembly hex screws to allow mounting the other base plate bracket.
7. Secure the other base plate bracket to the right leg assembly using the two hex head screws. Tighten the hex head screws.
8. Insert the short arms of the slides into the hinged tabs of the base plate. Position the slide so the notch near the short arm is on the bottom side.
9. Insert the long arms of the slides into the base plate brackets.
10. Insert and secure a cotter pin through the hole in the back of each of the slides.
11. Push the base plate toward the merchandiser cabinet. The front tabs of the base plate brackets should seat in the notches in the long arms of the slides.
12. Replace the caps, liner, and pail(s) removed previously.

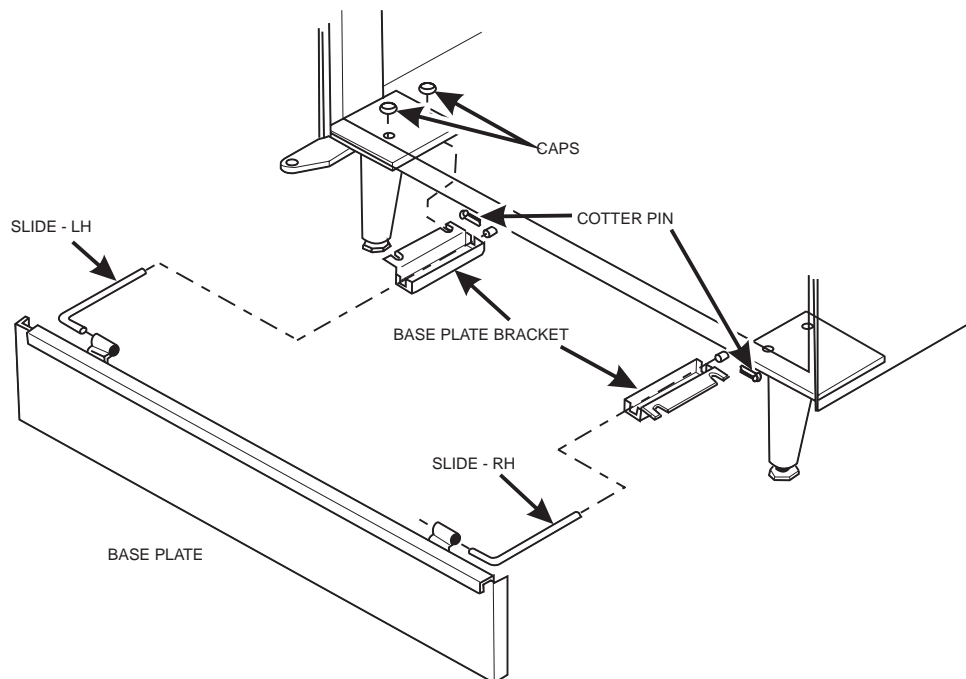

## 2. Install the Lock Cylinder

Install an optional lock cylinder in the merchandiser as follows:

1. Position the lift handle lock lever as shown.
2. Depress the lock spring at the square hole of the lock cylinder receptacle and pull the lock springs out through the front.
3. Position the lock cylinder as shown. Depress the spring loaded lock pin.
4. Push the cylinder into the cylinder receptacle in the lever. The pin should snap into the square hole.
5. If the cylinder pin does not seat in the square hole, press against both ends of the lock cylinder. Rotate the cylinder until the pin snaps into place.
6. **Leaving the door open**, test the lock mechanism with a key.

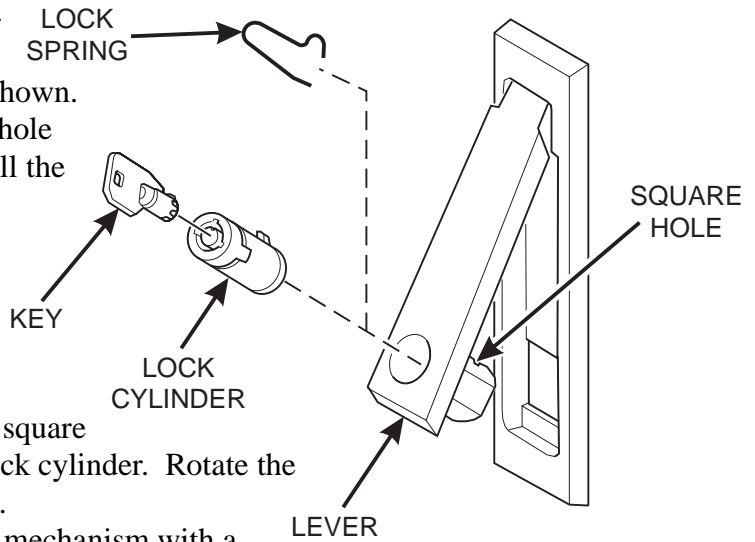

## 3. Install the Optional Cash Box Lock

1. Remove the cash box from the merchandiser.
2. Assemble the lock as shown in the illustration to the right.
3. Return the cash box to the merchandiser.

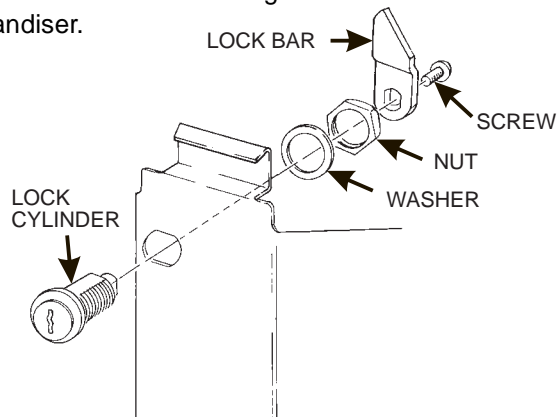

# 1. Set Up the Coin Mechanism

If the changer is not a MARS TRC 6000, proceed to **LOADING THE COIN MECHANISM**  
If the Changer is a MARS TRC 6000, you must set the high quarter switch.

**SETTING THE QUARTER SWITCH:**

QUARTER SWITCH POSITION	ACTION
<b>LOW</b>	The coin mechanism will only store 6 quarters. The rest are sent to the coin box. Fewer quarters are available for change.
<b>HIGH</b>	The coin mechanism will store 69 quarters. More quarters are available for change.

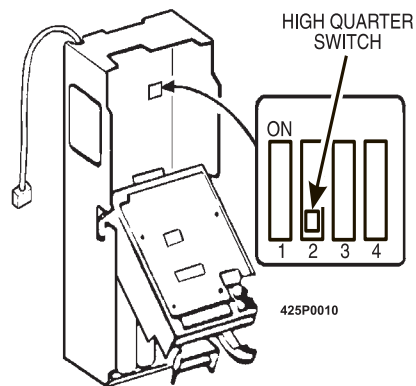







## 1. Load the Coin Mechanism

Once you arrive at the steps that tell you how to setup your coin mechanism, please perform the following steps:

**CAUTION:**

**THE MAIN POWER SWITCH MUST BE TURNED OFF BEFORE YOU GO ANY FURTHER!**

1. If your coin mechanism is a MARS 6000 or TRC 6010 XV, set the high quarter switch as shown, then continue. If your coin mech is another model, disregard this step. Continue.
2. If not already plugged in, plug the power cord into the electric outlet and turn ON the main power switch.
3. Press , and press  once. Press  until either *DUMB MECH* or *MDB MECH* is displayed (depending upon which coin mech type you have).
4. If you chose *MDB MECH* in the previous step, skip to step 5 and perform the rest of this procedure. If you chose *DUMB MECH* in the previous step, fill the coin tubes with coins. Make sure the coins are not shingled. You are now finished setting up your coin mech. Do not perform the rest of this procedure.
5. Press  until the standby message is displayed, then press .
6. Insert at least 20 coins of each denomination through the coin chute. Continue to fill the coin tubes either through the coin chute or the tops of the tubes.
7. Visually check the coin tubes to make sure coins are not shingled.
8. Press .
8. If credit is still shown in the display, turn the machine power OFF, then back ON.

# Programming

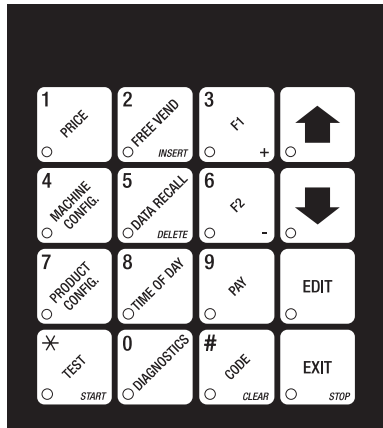

## THE SERVICE KEYPAD



The service keypad (shown on the left) is your major tool to program your merchandiser. If you just need to get your merchandiser up and running, you only have to set prices. That procedure is given below. For a thorough explanation of how to do all the custom programming features available to you, consult your *Programming Guide*. It will tell you how to:

- **Set up custom time-of-day vending periods;**
- **Look at sales and vending data;**
- **Test various machine functions;**
- **Customize trays for vending unique products;**
- **Enter custom display messages;**
- **And much more!**

## 1. Set Prices

1. Press . The display shows **\*\* 2.50.25**. This display shows the maximum and minimum prices set in the machine.
2. Press the number of the selection to be priced. (Example: B1.) The display shows **B1 X.XX**. Enter a price using the number keys. The selection is now priced.
3. Press another letter key, or  to price another selection.

### NOTE

**Refer to your Programming Guide for other pricing options.**

## 2. View the Chiller or Can Unit Temperature

After your merchandiser has been running for a while, you may want to see if the chiller or can unit (optional) is getting cold. The following procedure can be performed whether the main door is open or closed:

1. Press  on the selection switch panel. The temperature is displayed.
2. If desired, you can change the temperature by following the procedure given in your Programming Guide.

# Final Checkout

Now, you have connected your merchandiser to the utilities, placed it in its final location, loaded it with products, and set the prices. Before you lock the door and move on, you should check to see if your merchandiser will vend products. In case of problems, perform the operational readiness checks beginning on the next page.

## 1. Test Vend Selections

1. Press . The display shows *TEST.00*.
2. Deposit coins and/or currency to establish credit higher than the price of the selection. The display shows *TEST.XX*. **XX** is the amount of credit you established.
3. Use the selection switch panel to enter the selection number you want to vend. The display shows *PRICE.XX*. **XX** is the price of the selection.  
The selection is vended, then correct change and the credit are returned.
4. Test vend other selections, if desired.

## 2. Operational Readiness Check

1. Perform test vends on all selections.
2. Do any of the snack or candy products catch on the tray and fail to vend? If not, skip to step 3. If so, perform the following procedures on the affected areas until all products vend properly:
  - a. Install and/or adjust a product spacer.
  - b. Install a product pusher.
  - c. Install and/or remove spiral wall retainers.
  - d. Perform the appropriate spiral anti-hang-up procedure(s) (see below).
3. Test the operation of the coin mechanism (see the *Programming Guide for the proper procedure*).
4. Test the operation of the bill validator.
5. Return all test vended products to the trays.

### 3. Spiral Indexing Procedure (One Spiral, One Motor)

The spiral indexing procedures involve rotating spirals one position at a time until the product vends properly.

1. Home all the motors (see the *Programming Guide*).
2. Remove the affected spiral.
3. Is the coupler in the proper position?  
**NO** - Move the coupler to the position as shown in INSTALLING A SPIRAL COUPLER. Go to step 4.  
**YES** - Move the coupler to the next clockwise position (if it's on a right-hand motor), or the next counterclockwise position (if it's on a left-hand motor). Go to step 4.
4. Replace the spiral.
5. Perform a test vend (see the previous page).
6. Did the product hang up?  
**NO** - You're finished. Continue to test vend the remaining selections until everything works right.  
**YES** - Go to step 7.
7. Did you previously move the coupler to the next clockwise or counterclockwise position?  
**NO** - Move the coupler to the next clockwise position (if it's on a right-hand motor), or the next counterclockwise position (if it's on a left-hand motor). Return to step 6.  
**YES** - Return to step 2 in the operational readiness check and try another procedure. Do not move the coupler again.

### 4. Spiral Indexing Procedure (Two Spirals, One Or Two Motors)

The spiral indexing procedures involve rotating spirals one position at a time until the product vends properly.

1. Home all the motors (see the *Programming Guide*).
2. Remove the left hand spiral of the affected pair.
3. Is the coupler in the proper position?  
**NO** - Move the coupler to the position as shown in INSTALLING A SPIRAL COUPLER. Go to step 4.  
**YES** - Move the left coupler to the next counterclockwise position. Go to step 4.
4. Replace the left hand spiral.
5. Remove the right hand spiral, spiral coupler, and gear (if used) of the affected pair as a unit.
6. Rotate this unit until the right hand spiral mirrors the position of the left hand spiral.
7. Replace the right hand spiral, spiral coupler, and gear (if used).
8. Perform a test vend (see the previous page).
9. Did the product hang up?  
**NO** - You're finished. Continue to test vend the remaining selections until everything works right.  
**YES** - Go to step 10.
10. Did you previously move the left hand coupler to the next counterclockwise position?  
**NO** - Remove the left hand spiral of the affected pair. Turn the left spiral coupler to the next counterclockwise position. Return to step 4.  
**YES** - Return to step 2 in the operational readiness check and try another procedure. Do not move the coupler again.

## **5. Testing the Bill Validator**

1. Insert a \$1 bill into the validator.
2. Push the coin return button.  
**THE BILL VALIDATOR IS IN THE ESCROW MODE** - No money is returned - you must make a selection in order to receive any change. Go to step 3.  
**THE BILL VALIDATOR IS NOT IN THE ESCROW MODE** - You should receive four quarters in change. Go to step 3.
3. Make a selection. the correct selection should be vended and correct change should be returned.

### **NOW WHAT?**

There are many things you can do with your merchandiser to make it more flexible. Refer to the *Programming Guide* for this and other procedures.



# Errata Page

---



**Replace the coin mechanism setup procedure in your  
"Complete the installation" section, with the following corrected procedure !**

Once you arrive at the steps that tell you how to set up your coin mechanism, please perform the following steps instead:

**WARNING!**

**The main power switch must be turned OFF before you go any further!**

1. If your coin mechanism is a MARS 6000 or TRC 6010 XV, set the high quarter switch as shown, then continue. If your coin mech is another model, disregard this step. Continue.
2. If not already plugged in, plug the power cord into the electric outlet and turn ON the main power switch.

3. Press , and press  once. Press  until either *DUMB MECH* or *MOB MECH* is displayed (depending upon which coin mech type you have).

4. If you chose *MOB MECH* in the previous step, skip to step 5 and perform the rest of this procedure. If you chose *DUMB MECH* in the previous step, fill the coin tubes with coins. Make sure the coins are not shingled. You are now finished setting up your coin mech. Do not perform the the rest of this procedure.

5. Press , until the standby message is displayed, then press .

6. Insert at least 20 coins of each denomination through the coin chute. Continue to fill the coin tubes either through the coin chute or the tops of the tubes.

7. Visually check the coin tubes to make sure coins are not shingled.

8. Press .

# WARRANTY STATEMENT

---

**LIMITED WARRANTY. Subject to the limitations specified herein, this merchandiser is warranted for one (1) year against defective parts and workmanship. Any part or parts which are proven to be defective within one (1) year of the date of shipment will be repaired or replaced free of charge when the defective part is returned, with transportation charges prepaid, to the destination designated by CRANE MECHANDISING SYSTEMS Warranty Department.**

Refrigeration system's are warranted for (2) years against defective parts and workmanship. Any part or parts of the refrigeration system which are proven to be defective within (2) years of the date of shipment of the merchandiser will be repaired or replaced free of charge when the defective part(s) is returned, with transportation charges prepaid, to the destination designated by the Crane Merchandising Systems Warranty Department. Any part or parts that are proven to be free from defect will be assessed a diagnostic charge. This diagnostic charge will be added to the price of any replacement unit which might have been sent as an advanced replacement, as well as any shipping and handling fees that may have accrued as a result of shipping the original refrigeration unit. The charges will be the sole responsibility of the original purchaser.

This warranty does not include any cost of service rendered or repairs made by customer or it's agents on Merchandiser, or parts, unless authorization to incur such expense has been given in writing by CRANE MERCHANDISING SYSTEMS prior to incurring such expense. This warranty does not cover labor and service charges performed by CRANE MERCHANDISING SYSTEMS service technicians. Customer shall pay all labor costs with respect to warranty repairs.

This warranty does not apply to A) electrical components, wiring, or circuits and/or for all mechanical parts or assemblies damaged as a result of operating the Merchandiser at other than the design voltage and frequency specified on the Electrical Rating Tag, or B) in event of vandalism, fire or negligence, or C) incandescent lamps, neon lamps, fluorescent lamps, ballasts, starters or other expendable items or D) when other manufactured components are installed in Crane Merchandising Systems Merchandisers.

Replacement parts sold by CRANE MERCHANDISING SYSTEMS as After Market shall be covered for three months from the date shown on the parts invoice. Purchaser must obtain prior RETURN AUTHORIZATION for return of all parts, following guidelines given by Crane Merchandising Systems

New, unused parts purchased as AFTER MARKET, can be returned within 30 days from date of parts invoice, with prior authorization from CRANE MERCHANDISING SYSTEMS.

**CRANE'S LIABILITY FOR ANY AND ALL LOSSES AND DAMAGES TO CUSTOMERS RESULTING FROM ANY CAUSE WHATSOEVER INCLUDING CRANE'S NEGLIGENCE, ALLEGED DAMAGE OR DEFECTIVE GOODS, IRRESPECTIVE OF WHETHER SUCH DEFECTS ARE DISCOVERABLE OR LATENT, SHALL IN NO EVENT EXCEED THE REPAIR OR REPLACEMENT OF DEFECTIVE OR DAMAGED GOODS OR, AT THE ELECTION OF CRANE, THE PURCHASE PRICE OF THE PARTICULAR GOODS WITH RESPECT TO WHICH LOSSES OR DAMAGES ARE CLAIMED. CRANE RESERVES THE RIGHT TO REPLACE OR REPAIR DEFECTIVE OR DAMAGED GOODS WITH REMANUFACTURED PARTS OR MACHINES.**

**THIS WARRANTY IS IN LIEU OF ALL OTHER WARRANTIES EXPRESS OR IMPLIED, INCLUDING WITHOUT LIMITATION, WARRANTIES OF MERCHANTABILITY OR FITNESS FOR A PARTICULAR PUPOSE. CRANE MERCHANDISING SYSTEMS SHALL NOT BE RESPONSIBLE FOR CONSEQUENTIAL OR PUNITIVE DAMAGES. CRANE MERCHANDISING SYSTEMS NEITHER ASSUMES NOR AUTHORIZES ANY PERSON TO ASSUME FOR IT ANY OBLIGATION OR LIABILITY IN CONNECTION WITH THE SALE OF SAID EQUIPMENT OR ANY PART THEREOF.**

Crane Merchandising Systems  
A CRANE CO. Company  
12955 Enterprise Way  
Bridgeton, MO 63044

---